



**Toyota Motor Sales, USA, Inc.**  
 6565 Headquarters Drive  
 Plano, TX 75024  
 (469) 292-4000

Original Publication Date: July 17, 2017

To: All Toyota Dealer Principals, General Managers, Service Managers, and Parts Managers  
 Subject: Warranty Enhancement Program ZH6  
 Certain 2005 – 2010 Model Year Tacoma  
 Extension of Warranty Coverage for Frame Corrosion

In our continuing efforts to ensure the best in customer satisfaction, Toyota is announcing a Warranty Enhancement Program to extend the warranty coverage for Frame Corrosion on certain 2005 – 2010 model year Tacoma vehicles.

On May 21, 2017, a settlement of claims in a *class action lawsuit* involving 2005 – 2010 Toyota Tacoma vehicles regarding frame corrosion was approved. This finally approved *class action settlement* includes inspection of the customer’s frame, and if the frames meet or exceed the Rust Perforation Standard based on the Court-ordered inspection criteria, the frame will be replaced at no cost to the customer.

This settlement will also include CRC (Corrosion Resistant Compound) application. Toyota is currently preparing parts for CRC application process. CRC application will be covered under a separate Limited Service Campaign (LSC – H0F), and will only be available for vehicles registered in the Cold Climate States<sup>1</sup> that pass frame inspection criteria, and did not:

- Previously have the frame replaced and/or:
- Previously had the frame sprayed with CRC under any previous campaign

Activity	Estimated Launch Timing*	Notes
Frame Inspection	Available	As necessary
Frame Replacement	Available	Upon meeting or exceeding the Rust Perforation Standard based on Court-ordered inspection criteria
Customer Reimbursement	Available	Through Settlement Administrator; see <a href="http://www.toyotaframesettlement.com">www.toyotaframesettlement.com</a>
Frame CRC Application	Available	Only for vehicles that do not meet or exceed the Rust Perforation Standard based on Court-ordered inspection criteria; only for cold-climate states <sup>1</sup> ; under LSC H0F; expires May 21, 2019

\* Estimated Launch Timing is subject to change based on availability of remedy parts.

<sup>1</sup> – District of Columbia (DC), CT, DE, IL, IN, KY, MA, MD, ME, MI, MN, NH, NJ, NY, OH, PA, RI, VA, VT, WI, and WV.

**Background**

- Toyota has received reports that certain 2005 through 2010 model year Tacoma vehicles operated in specific cold climate areas (Cold Climate States) with high road salt usage may exhibit more-than-normal corrosion to the vehicle’s frame.
- Toyota investigated these reports and determined that the frames in some vehicles may not have corrosion-resistant protection sufficient for use in these areas.
- This combined with prolonged exposure to road salts and other environmental factors, may contribute to the development of more-than-normal rust in the frame of some vehicles.
- This condition is unrelated to and separate from normal surface rust which is commonly found on metallic surfaces after some years of usage and/or exposure to the environment.

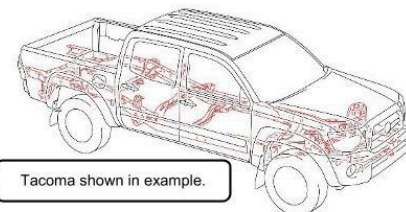

The following information is provided to inform you and your staff of the program notification schedule and your anticipated degree of involvement.

**Warranty Enhancement Program (WEP) Details**

This Warranty Enhancement Program provides enhanced coverage to the vehicle's "New Vehicle Limited Warranty" as it applies to frame corrosion. The specific condition covered by this program is rust that satisfies the Rust Perforation Standard as per the Settlement Agreement. If the condition is verified, the vehicle will be repaired with a new frame under the terms of this Warranty Enhancement Program.

- The coverage offers the latter of 12 years from the Date of First Use (DOFU) or 1 year from the date of final approval (5/21/2017).

*This coverage is for warranty work performed at an authorized Toyota dealer only. It is subject to the terms of the Settlement Agreement and conditions set forth in the New Vehicle Limited Warranty Section of the Owner's Warranty Information booklet, except where conflicting with the Settlement Agreement, in which case, the Settlement Agreement controls. For example, damage from abuse, an accident, theft and/or vandalism is not covered by the New Vehicle Limited Warranty or this warranty enhancement.*

**Warranty Enhancement Coverage:**

If a customer believes their vehicle has been operated in cold climate regions of the United States where high road salt is frequently used and/or a customer is concerned that their vehicle's frame has more-than-normal corrosion, Toyota dealerships are requested to inspect the vehicle's frame for corrosion using the Court-ordered Frame Inspection and Replacement Protocol. Based upon the results of the inspection, dealerships are requested to do one of the following at **no charge** to the vehicle owner:

- For warm climate states, if the vehicle's frame passes Toyota's inspection, no further action is required.
- For Cold Climate States (District of Columbia (DC), CT, DE, IL, IN, KY, MA, MD, ME, MI, MN, NH, NJ, NY, OH, PA, RI, VA, VT, WI, and WV), if the vehicle's frame passes Toyota's inspection, the vehicle may be eligible to have Corrosion Resistant Compound (CRC) protection applied. This will be applied under a separate Limited Service Campaign (LSC – H0F).
- For all states and territories, if the vehicle's frame meets or exceeds the standard for frame replacement, the frame will be replaced at **no charge** to the customer.

**Covered Vehicles**

There are approximately 887,000 vehicles covered by this Warranty Enhancement Program. Approximately 12,300 vehicles involved in this Warranty Enhancement Program were distributed to Puerto Rico.

Model Name	Model Year	UJO	Production Period
Tacoma	2005 – 2010	887,000	Mid-September 2004 – Mid-July 2010

**Owner Letter Mailing Date**

Toyota will begin to notify owners in early September 2017 and will be mailed over several months. A sample of the owner notification letter has been included for your reference.

**Technician Training Requirements**

The repair quality of covered vehicles is extremely important to Toyota. All Toyota dealership technicians performing this repair are required to successfully complete the most current version of the E-Learning course "Safety Recall and Service Campaign Essentials". To ensure that all vehicles have the repair performed correctly, technicians performing this repair are required to currently hold at least one of the following certification levels:

- Certified Technician (any specialty)
- Expert Technician (any specialty)
- Master Technician
- Master Diagnostic Technician

**Final repair must be signed off and validated by a MDT, Shop Foreman, or Service Manager using the Frame Replacement Inspection Form.**

Always check which technicians can perform the recall remedy by logging on to <https://www.uotdealerreports.com>. It is the dealership's responsibility to select technicians with the above certification level or greater to perform this repair. Carefully review your resources, the technician skill level, and ability before assigning technicians to this repair. It is important to consider technician days off and vacation schedules to ensure there are properly trained technicians available to perform this repair at all times.

© 2017 Toyota Motor North America

**Remedy Procedures**

The Technical Instructions contain inspection criteria for completing the frame inspection, as well as instructions to access the frame inspection website. The frame must be inspected by a qualified Toyota technician, who will inspect the frame rails and cross member mounting locations. If any perforation in the frame is found to be 10 mm or larger, then the frame will be replaced as per the Settlement Agreement. Please use the flow chart below.

If the vehicle passes the frame inspection, and the CRC application is applicable, instructions will be provided in the Technical Instructions under the LSC.

To assist dealers in determining the correct part number(s) to order, a website has been set up to look up part numbers by VIN. Please go to <http://toyota-frame-parts-lookup.imagespm.info>. Select the appropriate campaign/vehicle, enter the VIN, and the correct part numbers to order will be displayed. **The website is for part(s) application reference only and won't order the parts, confirm campaign completion status, or confirm campaign applicability.**

- The parts will need to be ordered through the Dealer Daily Parts System.
- ETAs for the parts will be available via the normal system.
- Frame ETAs will be made available on the Dealer Daily website, in the MAC reference area.

**Note: When first logging in; enter your dealer code and the default password; XXXXXX. Upon logging in the website will ask for you to reset the password and provide an email address.**

**Warranty Reimbursement Procedure**

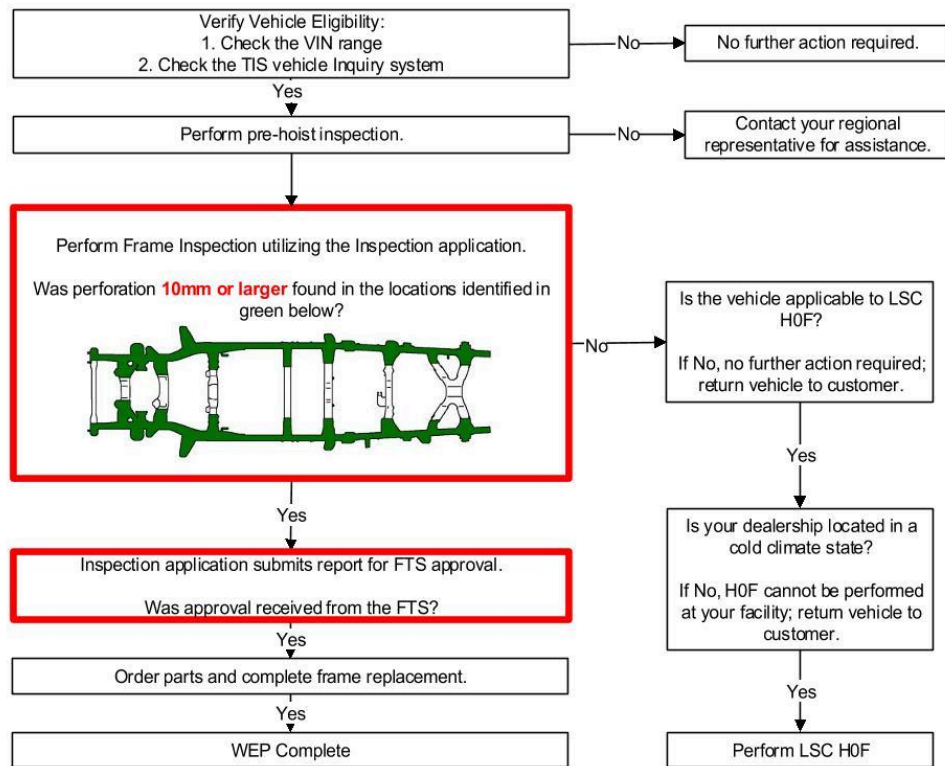

## Warranty Enhancement Program ZH6 - D - Page | 4

Op Code	Description	Flat Rate Hour
GHG17A	2005-2008 MY Frame Inspection – No Significant Perforation Found	0.5 hr/vehicle
ZH6404	2005-2008 MY Frame Inspection – Qualifying Perforation Found – Awaiting Frame Replacement	0.5 hr/vehicle
GHG19A	2009-2010 MY Frame Inspection – No Significant Perforation Found	0.5 hr/vehicle
ZH6213	2009-2010 MY Frame Inspection – Qualifying Perforation Found – Awaiting Frame Replacement	0.5 hr/vehicle
GHG17B	2005-2008 MY Frame Inspection + Replace Frame and Install Body Plugs – 2WD (Dealer)	39.5 hrs/vehicles
GHG17C	2005-2008 MY Frame Inspection + Replace Frame and Install Body Plugs – 4WD (Dealer)	41.1 hrs/vehicle
GHG17D	2005-2008 MY Frame Inspection + Replace Frame and Install Body Plugs – 2WD (Sublet)	0.5 hrs/vehicle
GHG17E	2005-2008 MY Frame Inspection + Replace Frame and Install Body Plugs – 4WD (Sublet)	0.5 hrs/vehicle
GHG17F	2005-2008 Replace Frame and Install Body Plugs – 2WD (Dealer)	39.0 hrs/vehicle
GHG17G	2005-2008 Replace Frame and Install Body Plugs – 4WD (Dealer)	40.6 hrs/vehicle
GHG17H	2005-2008 Replace Frame and Install Body Plugs – 2WD (Sublet)	0.0 hrs/vehicle
GHG17J	2005-2008 Replace Frame and Install Body Plugs – 4WD (Sublet)	0.0 hrs/vehicle
GHG19B	2009-2010 MY Frame Inspection + Replace Frame and Install Body Plugs – 2WD (Dealer)	39.5 hrs/vehicles
GHG19C	2009-2010 MY Frame Inspection + Replace Frame and Install Body Plugs – 4WD (Dealer)	41.1 hrs/vehicle
GHG19D	2009-2010 MY Frame Inspection + Replace Frame and Install Body Plugs – 2WD (Sublet)	0.5 hrs/vehicle
GHG19E	2009-2010 MY Frame Inspection + Replace Frame and Install Body Plugs – 4WD (Sublet)	0.5 hrs/vehicle
GHG19F	2009-2010 Replace Frame and Install Body Plugs – 2WD (Dealer)	39.0 hrs/vehicle
GHG19G	2009-2010 Replace Frame and Install Body Plugs – 4WD (Dealer)	40.6 hrs/vehicle
GHG19H	2009-2010 Replace Frame and Install Body Plugs – 2WD (Sublet)	0.0 hrs/vehicle
GHG19J	2009-2010 Replace Frame and Install Body Plugs – 4WD (Sublet)	0.0 hrs/vehicle

- Sublet: The sublet cost for Op. Codes GHG17D/19D, GHG17E/19E, GHG17H/9H, and GHG17J/19J (Replace Frame by a Sublet shop) should be claimed under sublet type YF using the following formula:
  - GHG17D/19D and GHG17G/19H = Maximum 38.2 Hours X Dealer Hourly Rate
  - GHG17E/19E and GHG17J/19J = Maximum 39.8 Hours X Dealer Hourly Rate
- The transportation cost of frame between dealer and outside repair shop will be reimbursed for the maximum cost US \$50.00 under the sublet cost column for the Op. No. GHG17D/19D, GHG17E/19E, GHG17H/19H and GHG17J/19J with Sublet Type YC.
- The transportation cost of vehicle between dealer and outside repair shop will be reimbursed for the maximum cost US \$250.00 under the sublet cost column for the Op. No. GHG17D/19D, GHG17E/19E, GHG17H/19H and GHG17J/19J with Sublet Type YG.

**Loaner Vehicle Reimbursement Procedure**

Due to parts procurement limitations, for vehicles that do not pass the Toyota inspection criteria, rental vehicles will be made available for up to 60 days (maximum \$60 per day) if the vehicle is required to remain at the Toyota Dealer overnight. In appropriate circumstances, where a customer desires a similar vehicle, please make an effort to accommodate their request.

Op Code	Description
<b>Op Codes for 2009 – 2010</b>	
GHG20A	2009 - 2010 MY Vehicle Rental 1-30 days
GHG20B	2009 - 2010 MY Vehicle Rental 31-60 days
GHG20C	2009 - 2010 MY Vehicle Rental 61-90 days
GHG20D	2009 - 2010 MY Vehicle Rental 91-120 days
<b>Op Codes for 2005 – 2008</b>	
GHG18A	2005 - 2008 MY Vehicle Rental 1-30 days
GHG18B	2005 - 2008 MY Vehicle Rental 31-60 days

**NOTE: Rental invoice *MUST* be attached to all rental claims. These claims may be subject to debit if rental invoice is not attached.**

**Customer Reimbursement**

Customers who previously paid for the replacement of a frame, prior to January 3, 2017, are required to submit a claim to the settlement administrator by July 20, 2017 (60 days after final court approval) for reimbursement consideration by the Court-appointed Settlement Claims Administrator. Those customers who are eligible for reimbursement will be provided a check by the settlement administrator. If customers have questions regarding the status of their reimbursement requests, please have them contact the settlement administrator at 1- 800-481-7948.

**Media Contacts**

It is imperative that all media contacts (local and national) receive a consistent message. In this regard, all media contacts must be directed to Victor Vanov (469) 292-1318 in Toyota Corporate Communications. Please do not provide this number to customers. Please provide this contact only to media.

**Customer Contacts**

Customers who receive the owner letter may contact your dealership with questions regarding the letter and/or the Warranty Enhancement Program. Please welcome them to your dealership and answer any questions that they may have. A Q&A is provided to assure a consistent message is communicated.

Customers with additional questions or concerns are asked to please contact the Toyota Customer Experience Center (1-888-270-9371) - Monday through Friday, 7:00 am to 7:00 pm, Saturday 7:00 am to 4:30 pm Central Time.

Customers with additional questions or concerns may visit the settlement website at [www.toyotaframesettlement.com](http://www.toyotaframesettlement.com) or may contact the Settlement Administrator at 1-800-481-7948.

Thank you for your cooperation.  
TOYOTA MOTOR SALES, U.S.A., INC.



**Warranty Enhancement Programs ZH6, ZH7, ZH8, ZH9  
Multiple Models and Model Years  
Extension of Warranty Coverage for Frame Corrosion**

**Frequently Asked Questions**

**Original Publication Date: July 17, 2017**

## ◀ IMPORTANT UPDATE ▶

DATE	TOPIC
10/19/2017	<ul style="list-style-type: none"> <li>Tundra Frame Replacement and CRC Application is now available.</li> </ul>
10/12/2017	<ul style="list-style-type: none"> <li>Sequoia (2005-2008) Frame Replacement and CRC Application is now available.</li> </ul>

**The most recent update will be highlighted with a red box.**

On May 21, 2017, a settlement of claims in a *class action lawsuit* involving 2005 – 2010 Toyota Tacoma, 2007-2008 Tundra, and 2005-2008 Sequoia vehicles regarding frame corrosion was approved. This finally approved *class action settlement* includes inspection of the customer's frame, and if the frames meet or exceed the Rust Perforation Standard based upon the Court-ordered inspection criteria, the frame will be replaced at no cost to the customer. Toyota is currently preparing parts for frame replacement (Tundra).

This settlement will also include CRC (Corrosion Resistant Compound) application. Toyota is currently preparing parts for the CRC application process. Once available, CRC application will be covered under a separate Limited Service Campaign (LSC), and will only be available for vehicles registered in the Cold Climate States<sup>1</sup> that pass frame inspection criteria, and did not:

- Previously have the frame replaced and/or:
- Previously had the frame sprayed with CRC under any previous campaign

Model	Activity	Estimated Launch Timing*	Notes
2005-2010 Tacoma	Frame Inspection	Available	As necessary
	Frame Replacement-Tacoma	Available	Upon meeting or exceeding the Rust Perforation Standard based on Court-ordered inspection criteria
	Frame Replacement – Tundra	Available	Upon meeting or exceeding the Rust Perforation Standard based on Court-ordered inspection criteria
2007-2008 Tundra	Frame Replacement – 2008 Sequoia	Available	Upon meeting or exceeding the Rust Perforation Standard based on Court-ordered inspection criteria
	Frame Replacement – 2005 – 2007 Sequoia	Available	Upon meeting or exceeding the Rust Perforation Standard based on Court-ordered inspection criteria
2005-2008 Sequoia	Customer Reimbursement	Available	Through Settlement Administrator; see <a href="http://www.toyotaframesettlement.com">www.toyotaframesettlement.com</a>
	Frame CRC Application	Available (all models)	Only for vehicles that do not meet or exceed the Rust Perforation Standard based on Court-ordered inspection criteria; only for cold-climate states <sup>1</sup> ; under separate Limited Service Campaign (LSC – H0F); expires May 21, 2019

\* Estimated Launch Timing is subject to change based on availability of remedy parts.

<sup>1</sup> – District of Columbia (DC), CT, DE, IL, IN, KY, MA, MD, ME, MI, MN, NH, NJ, NY, OH, PA, RI, VA, VT, WI, and WV.

**Q1: What is the condition?**

A1: On the subject vehicles, Toyota has received reports that certain vehicles operated in specific cold climate areas (Cold Climate States) with high road salt usage may exhibit more-than-normal corrosion to the vehicle's frame. Toyota investigated these reports and determined that the frames in some vehicles may not have corrosion-resistant protection sufficient for use in these areas. This, combined with prolonged exposure to road salts and other environmental factors, may contribute to the development of more-than-normal rust in the frame of some vehicles. This condition is unrelated to and separate from normal surface rust which is commonly found on metallic surfaces after some years of usage and/or exposure to the environment.

**Q2: What is Toyota offering and why?**

A2: On May 21, 2017, a settlement of the class action relating to Vehicle Frame Corrosion was finally approved by the Court. As part of the class action settlement, Toyota will initiate a Warranty Enhancement Program (WEP) to inspect affected vehicle's frames, and, if necessary, replace the vehicle's frame. If the vehicle's frame passes the inspection, and is registered in a Cold Climate State, the customer will be offered a Frame CRC application. This WEP will be available for 1 year from May 21, 2017 or 12 years from the vehicle's Date of First Use (DOFU), whichever is longer. The CRC application will be offered under a separate Limited Service Campaign (LSC – H0F) for a period of two years from the date of court approval.

**Q3: What is Toyota going to do?**

A3: Toyota will send (in phases consistent with parts availability and repair capacity), starting in September, 2017, an owner notification by first class mail advising owners to make an appointment with their authorized Toyota dealer to have their frame inspected.

If the owner experiences the condition described above, they should contact their local authorized Toyota dealership for diagnosis. If the vehicle exhibits significant rust perforation based on Toyota inspection criteria, the dealer will replace the vehicle's frame with a new one at **NO CHARGE** to the customer.

**Q4: Which and how many vehicles are covered by this Warranty Enhancement Program?**

A4: There are approximately 1,385,100 vehicles covered by this Warranty Enhancement Program.

Model	Model Year	UJO	Production Period
Tacoma	2005 – 2010	887,000	Mid-September 2004 – Mid-July 2010
Tundra	2007 – 2008	341,200	Late October 2006 – Mid-August 2008
Sequoia	2005 – 2008	156,900	Late March 2004 – Early August 2008

**Q5: What are the parameters of this Warranty Enhancement Program (WEP) and Limited Service Campaign (LSC)?**

A5: The terms of the WEP are:

- **The coverage offers the latter of 12 years from the Date of First Use (DOFU) or 1 year from the date of final approval (5/21/2017).**

*This coverage is for warranty work performed at an authorized Toyota dealer only. It is subject to the terms of the Settlement Agreement and conditions set forth in the New Vehicle Limited Warranty Section of the Owner's Warranty Information booklet, except where conflicting with the Settlement Agreement, in which case, the Settlement Agreement controls. For example, damage from abuse, an accident, theft and/or vandalism is not covered by the New Vehicle Limited Warranty or this warranty enhancement.*

The terms of the LSC are:

- **The coverage offers two years from the date of final approval (5/21/2017).**
- **Vehicle must be currently registered in a cold-climate state.**

**Q5a: Are there any exclusions and limitations?**

A5a: This WEP **does not** cover cosmetic damage or breakage due to outside forces, damage incurred from abuse, vandalism, flood, misuse, tampering, a crash, and/or other impact, animal damage, fire, or carbon build-up.

The WEP **does not** apply to vehicles that have flood damaged titles or vehicles that were sent to a salvage yard, junkyard, wreckage facility or similar entity.

This WEP is applicable only to vehicles that were originally distributed in the U.S. or the U.S. Territories. The vehicle must have been ever registered in the United States, unless proof is provided that it could not be registered due to excessive corrosion on the vehicle's frame.

Imported vehicles (ex. Mexico and Canada) are not covered, even if currently registered in the US.

**Q5b: What if used to live in a Cold Climate State, but now do not?**

A5b: Application of the Corrosion Resistant Compounds will be based on where the subject vehicle is currently registered.

**Q6: If you suspect your vehicle exhibits this condition, do you need to make an appointment with your dealership?**

A6: Yes. You should take your vehicle to a Toyota dealership if you suspect your vehicle is exhibiting the condition described. The dealership will inspect the vehicle as per the parameters of the Warranty Enhancement Program. **If you have not experienced this condition, please apply the sticker to your Owner's Warranty Information booklet for future reference.**

**Q7: Is the Warranty Enhancement Program coverage transferable if I sell my vehicle?**

A7: Yes. This Warranty Enhancement Program coverage is fully transferrable to subsequent vehicle owners for the condition and terms specified in the notification letter.

**Q8: How long will the repair take?**

A8: The inspection of the vehicle's frame will take approximately 2 hours. If frame corrosion that meets or exceeds the Rust Perforation Standard is found and the frame requires replacement, the repair will take approximately one week. A complimentary loaner vehicle will be offered if frame replacement is required. Depending upon the dealer's work schedule, however, it may be necessary to make the vehicle available for a longer period of time.

**Q9: Tacoma only - What if I previously had my frame replaced or sprayed with CRC (Corrosion Resistant Compound)?**

A9: Your vehicle is covered under this WEP regardless of whether the frame was sprayed with CRC or replaced during a previous Toyota campaign.

**Q10: How does Toyota obtain my mailing information?**

A10: Toyota uses an industry provider who works with each state's Department of Motor Vehicles (DMV) to receive registration or title information, based upon the DMV records. Please make sure your registration or title information is correct.

**Q11: What if I have additional questions or concerns?**

A11: If you have additional questions or concerns, please contact the Toyota Customer Experience Center at 1-888-270-9371 Monday through Friday, 7:00 AM to 7:00 PM, Saturday 7:00 AM to 4:30 PM Central Standard Time.

Customers with additional questions or concerns may visit the settlement website at [www.toyotaframesettlement.com](http://www.toyotaframesettlement.com) or may contact the Settlement Administrator at 1-800-481-7948.

# TOYOTA

Toyota Motor Sales, U.S.A., Inc.  
19001 South Western Avenue  
Torrance, CA 90501  
(310) 468-4000

## WARRANTY ENHANCEMENT NOTIFICATION – ZH6 LIMITED SERVICE CAMPAIGN – H0F

[VIN]

Dear Toyota Owner:

Toyota would like to advise you of an enhancement to portions of your Toyota New Vehicle Limited Warranty as part of a finally approved and implemented class action settlement.

Toyota has received reports regarding frame corrosion on 2005 – 2010 model year Tacoma vehicles. While not all vehicles will experience this condition, we are offering the following program:

### Warranty Enhancement Program Details

This Warranty Enhancement Program covers vehicles purchased new or used provides enhanced coverage to the vehicle’s “New Vehicle Limited Warranty” as it applies to frame corrosion. The specific condition covered by this program involves rust perforation, i.e. “Rust Perforation Standard.” If perforation of the frame from rust corrosion meets or exceeds the Rust Perforation Standard, the frame will be replaced at no cost under the terms of this Warranty Enhancement Program.

- The coverage offers the latter of 12 years from the Date of First Use (DOFU) or 1 year from the date of final approval (5/21/2017).

*This coverage is for warranty work performed at an authorized Toyota dealer only, and is limited to your specific vehicle whose Vehicle Identification Number (VIN) is printed below. It is subject to the terms of the Settlement Agreement and conditions set forth in the New Vehicle Limited Warranty Section of the Owner’s Warranty Information booklet, except where conflicting with the Settlement Agreement, in which case, the Settlement Agreement controls. For example, damage from abuse, an accident, theft and/or vandalism is not covered by the New Vehicle Limited Warranty or this warranty enhancement.*

\*Please see your Toyota dealer for additional details

VIN# \_\_\_\_\_

Date of First Use \_\_\_\_\_

Peel and Stick  
Label onto the  
Owner’s Warranty  
Information Booklet

Additionally, for a period of two years from the date of the final court approval (May 21, 2017), if the perforation does not meet or exceed the Rust Perforation Standard, and the vehicle is registered in a Cold Climate State<sup>1</sup>, the dealer will apply CRC (Corrosion Resistant Compound) to the frame, if, for Tacoma vehicles, it was not previously applied and the frame was not previously replaced, subject to these and other limitations included in the Settlement Agreement.

<sup>1</sup> – District of Columbia (DC), CT, DE, IL, IN, KY, MA, MD, ME, MI, MN, NH, NJ, NY, OH, PA, RI, VA, VT, WI, and WV.

### What should you do?

**Please apply the sticker above to your Owner’s Warranty Information Booklet for future reference. If you have not experienced the condition described above, there is no action necessary at this time.**

**Please contact any authorized Toyota dealer and make arrangements for inspection, diagnosis and, if applicable, repair.**

If you would like to update your vehicle ownership or contact information, please go to [www.toyota.com/ownersupdate](http://www.toyota.com/ownersupdate). You will need your full 17-digit Vehicle Identification Number (VIN) to input the new information.

Customers with additional questions or concerns are asked to please contact the Toyota Customer Experience Center (1-888-270-9371) - Monday through Friday, 7:00 am to 7:00 pm, Saturday 7:00 am to 4:30 pm Central Time. Customers with additional questions or concerns may visit the settlement website at [www.toyotaframesettlement.com](http://www.toyotaframesettlement.com) or may contact the Settlement Administrator at 1-800-481-7948.

Thank you for driving a Toyota.

Sincerely,

TOYOTA MOTOR SALES, U.S.A., INC.

SAMPLE

# TOYOTA

Toyota Motor Sales, USA, Inc.  
19001 South Western Avenue  
Torrance, CA 90501  
(310) 468-4000

<b>WARRANTY ENHANCEMENT PROGRAM and LIMITED SERVICE CAMPAIGN FREQUENTLY ASKED QUESTIONS</b>	<b>ZH6 and H0F</b>
---	----------------------------

**Q1: Are these a recall?**

A1: No. These are not a recall. Toyota is advising you of this enhancement to the Warranty Coverage pursuant to the terms of a Court-approved Settlement agreement.

**Q2: If you suspect your vehicle exhibits this condition, do you need to make an appointment with your dealership?**

A2: Yes. You should take your vehicle to an authorized Toyota dealership if you suspect your vehicle is exhibiting the condition described. The dealership will inspect the vehicle as per the parameters of the Warranty Enhancement Program. **If you have not experienced this condition, please apply the sticker to your Owner's Warranty Information booklet for future reference.**

**Q3: Is the Warranty Enhancement Program and Limited Service Campaign coverage transferable if I sell my vehicle?**

A3: Yes. These campaign coverages are fully transferable to subsequent vehicle owners for the condition and terms specified in the notification letter.

**Q4: What should I do if my vehicle has the condition described?**

A4: If you experience this condition, please contact any authorized Toyota dealer and make arrangements for inspection and, if applicable, repair.

**Q5: How long will the repair take?**

A5: The inspection of the vehicle's frame will take approximately 2 hours. If frame corrosion that meets or exceeds the Rust Perforation Standard is found, and the frame requires replacement, the repair will take approximately one week. A complimentary loaner vehicle will be offered if frame replacement is required. Depending upon the dealer's work schedule, however, it may be necessary to make the vehicle available for a longer period of time.

If frame corrosion does not meet or exceed the Rust Perforation Standard, and the dealer applies CRC, subject to the vehicle at issue, the repair takes approximately 6 hours, and the vehicle will be held overnight to allow time for the CRC to cure. However, depending upon the dealer's work schedule, it may be necessary to make the vehicle available for a longer period of time.

**Q6: What if I previously had my frame replaced or sprayed?**

A6: Your vehicle is covered under this WEP regardless if the frame was sprayed with CRC or replaced during a previous Toyota campaign. However, if you previously had your Tacoma vehicle's frame previously sprayed or replaced under a Toyota campaign, it will be excluded from CRC application coverage under the settlement agreement.

**Q7: What if I have additional questions or concerns?**

A7: If you have additional questions or concerns, please contact the Toyota Customer Experience Center at 1-888-270-9371 Monday through Friday, 7:00 am to 7:00 pm, Saturday 7:00 am to 4:30 pm Central Time.

Customers with additional questions or concerns may visit the settlement website at [www.toyotaframesettlement.com](http://www.toyotaframesettlement.com) or may contact the Settlement Administrator at 1-800-481-7948.

**ASM Reference Guide for Warranty Extension Program (WEP) ZH6 - Covered Components: *if Frame Replacement is Needed***

### Primary Parts

Frame, Skid Plate, Spare Tire Carrier, and Body Supports

**Frame Mounted Brake Lines**  
(Access cab w/o VSC shown for reference)

### Supplemental Parts

**Radiator / Air Conditioning**

Shift Lever—Rod Type Only

**Molding**  
(X-Runners have a different style of molding)

Not all clips and grommets shown will require replacement.

**Rear Wheel House Liner**

Not all grommets shown will require replacement.

### Attachment Hardware

**Exhaust System**  
(V6 shown for reference)

**Front End**  
(4WD shown for reference)

**Rear Suspension**  
(2WD Only)

**Engine Mount**

**Power Steering**  
(V6 shown for reference)

**Fuel Tank**

**Front and Rear Bumper**

**Wire Harness Clamps**

**Maintenance Items for Customer Consideration**

During frame replacement, it may be advantageous for you to have other maintenance and repairs performed. Examples include:

- Shocks
- Drive Belts
- Brake Pads/Linings
- Ball Joints/Tie Rod Ends
- Etc.

**Note:**

- Quantities and individual components can vary slightly based on model year and model configuration (e.g. 2WD vs. 4WD, regular cab vs. double cab, etc.).
- Parts provided under the campaign are in red.

# FRAME REPLACEMENT INSPECTION

VIN: \_\_\_\_\_ DATE: \_\_\_\_\_

DEALER NAME: \_\_\_\_\_ DEALER CODE: \_\_\_\_\_

<b>FUNCTIONAL OPERATION</b>	<b>Before</b>	<b>After</b>
1 Check warning light, gauges, horn, audio system, interior lights	<input type="checkbox"/>	<input type="checkbox"/>
2 Check windshield wipers, washers, power windows & door locks	<input type="checkbox"/>	<input type="checkbox"/>
3 Check headlights, turn signals, flashers, brake lights	<input type="checkbox"/>	<input type="checkbox"/>
4 Check side marker, tail, backup, cargo, license plate lights	<input type="checkbox"/>	<input type="checkbox"/>
5 Check HVAC system, radiator cooling fans	<input type="checkbox"/>	<input type="checkbox"/>
6 Headlight Aim per specification	<input type="checkbox"/>	<input type="checkbox"/>
<b>UNDER HOOD INSPECTION</b>		
7 Check engine oil & ATM fluid levels	<input type="checkbox"/>	<input type="checkbox"/>
8 Check brake & power steering fluid levels	<input type="checkbox"/>	<input type="checkbox"/>
9 Check coolant level	<input type="checkbox"/>	<input type="checkbox"/>
10 Check windshield washer fluid level	<input type="checkbox"/>	<input type="checkbox"/>
11 Inspect for fuel, oil, coolant, power steering and other fluid leaks	<input type="checkbox"/>	<input type="checkbox"/>
<b>TEST DRIVE</b>		
12 Alignment - drives straight with no pull	<input type="checkbox"/>	<input type="checkbox"/>
13 Inspect for abnormal noise and vibrations	<input type="checkbox"/>	<input type="checkbox"/>
14 Brake operation - pedal is firm and does not have excessive travel	<input type="checkbox"/>	<input type="checkbox"/>
15 Parking brake operation	<input type="checkbox"/>	<input type="checkbox"/>
16 Check 4WD system (if equipped)	<input type="checkbox"/>	<input type="checkbox"/>
17 Transmission shifting	<input type="checkbox"/>	<input type="checkbox"/>
18 No exhaust leaks	<input type="checkbox"/>	<input type="checkbox"/>
<b>INSPECTIONS</b>		
19 Health Check - no DTC's	<input type="checkbox"/>	<input type="checkbox"/>
20 Tire Pressure Warning System operational	<input type="checkbox"/>	<input type="checkbox"/>
21 Note any Body Damage:	<input type="checkbox"/>	<input type="checkbox"/>
<b>FRAME REPLACEMENT</b>		
22 Serial number has been entered on website	<input type="checkbox"/>	<input type="checkbox"/>
23 ALL PARTS detailed in the TI have been replaced	<input type="checkbox"/>	<input type="checkbox"/>
24 ALL hardware as been torqued to specification	<input type="checkbox"/>	<input type="checkbox"/>
25 All fluids have been replaced as detailed in the TI	<input type="checkbox"/>	<input type="checkbox"/>

_____ TECHNICIANS SIGNATURE	_____ MANAGERS SIGNATURE*
_____ TECHNICIANS NAME (please print)	_____ MANAGERS NAME* (please print)

\* Manager could be Service Manager, MDT, or Shop Foreman as per Technician Training Requirements

# TECHNICAL INSTRUCTIONS FOR WARRANTY ENHANCEMENT PROGRAM ZH6

\*\*\*\*\*

## CERTAIN 2005 THROUGH 2010 MODEL YEAR TACOMA

\*\*\*\*\*

### FRAME REPLACEMENT

The repair quality of covered vehicles is extremely important to Toyota. All dealership technicians performing this recall are required to successfully complete the most current version of the E-Learning course "Safety Recall and Service Campaign Essentials". To ensure that all vehicles have the repair performed correctly; technicians performing this repair are required to currently hold at least one of the following certification levels:

- Certified Technician (any specialty)
- Expert Technician (any specialty)
- Master Technician
- Master Diagnostic Technician

Final repair must be signed off and validated by a MDT, Shop Foreman or Service Manager using the Frame Replacement Inspection Form.

It is the dealership's responsibility to select technicians with the above certification level or greater to perform this recall repair. Carefully review your resources, the technician skill level, and ability before assigning technicians to this repair. It is important to consider technician days off and vacation schedules to ensure there are properly trained technicians available to perform this repair at all times.

### I. OPERATION FLOWCHART

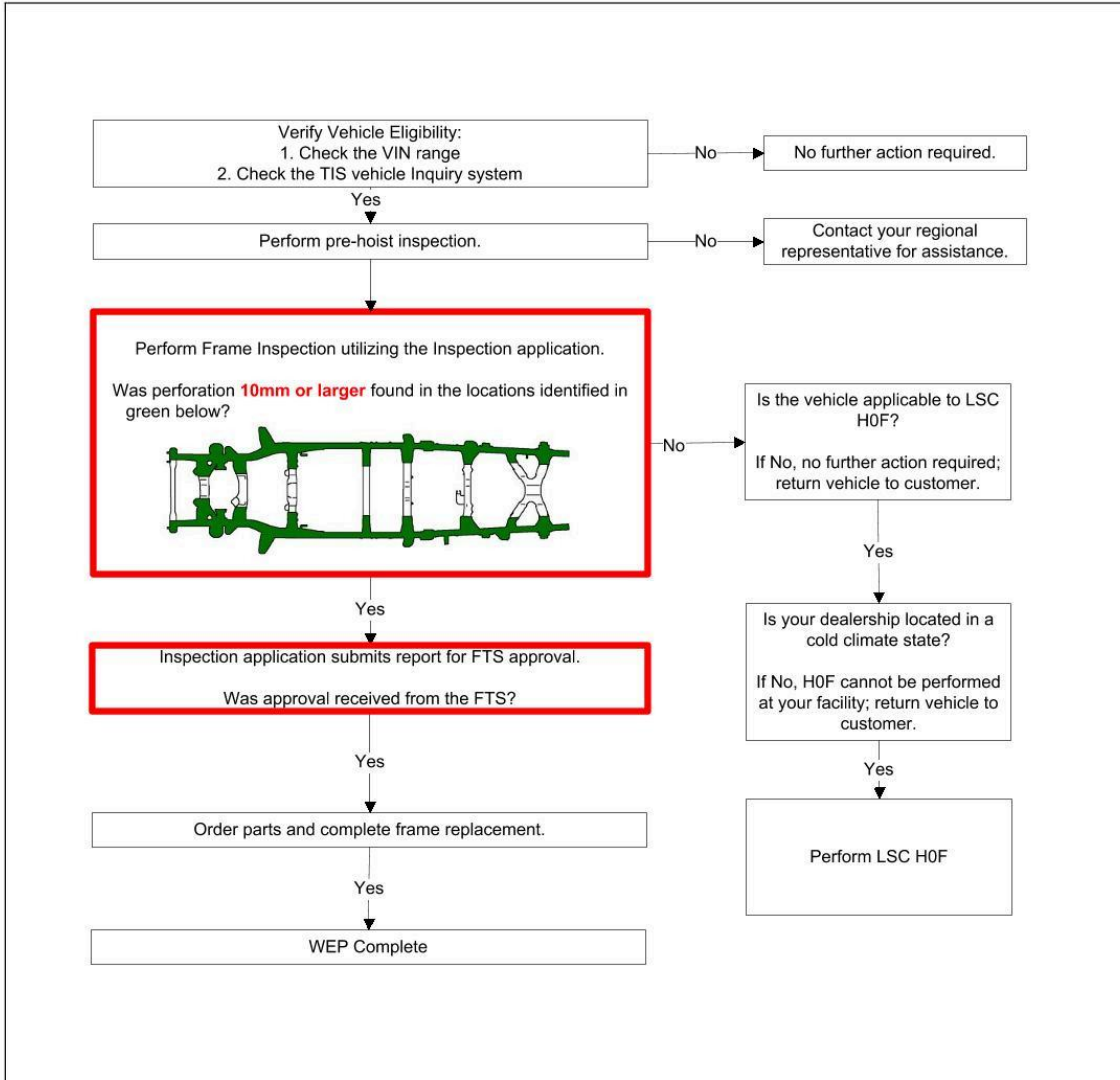

## II. PREPARATION

### A. TOOLS & EQUIPMENT

- A/C service equipment
- Alignment rack
- Brake bleeder
- Engine hanger
  - 1GR-FE Engine
    - 12281-31060 – Engine hanger no. 1 (Qty: 1)
    - 12282-31040 – Engine hanger no. 2 (Qty: 1)
    - 90119-08A87 – Bolt (Qty: 4)
  - 2TR-FE Engine
    - 12281-75040 – Engine hanger no. 1 (Qty: 1)
    - 12281-75040 – Engine hanger no. 2 (Qty: 1)
    - 91552-A1020 – Bolt (Qty: 2)
- Engine hoist (Qty: 2) or Hydraulic mini crane (Qty 2)
- Engine sling (Qty: 2)
- Protective eyewear
- Protective gloves
- Ratcheting tie down strap (2 in X 27 ft, minimum work load capacity: 3,000 lbs)
- Special Service Tools (SST)
  - 07110-58060 – Air conditioner service tool set **or** Commercially available air conditioning manifold gauge set
  - 09325-40010 – Transmission oil plug (Transmission A340E)
  - 09610-20012 – Pitman arm puller (2WD)
  - 09628-62011 – Ball joint puller (4WD, Pre-Runner)
  - 09520-32040 – A component of SST 09520-24010, Differential side gear shaft puller
  - 09520-01010 – Drive shaft remover attachment
  - 09628-00011 – Ball joint puller
  - 09922-10010-01 – Variable open wrench
- Standard hand tools
- Techstream
- Torque wrench
- Torx® T55H socket
- Socket wrench 36mm
- Hexagon wrench 8, 10
- Deep socket wrench 10, 12, 14, 17, 19mm
- Union Nut Wrench 10mm
- Weights
- Drill

### B. SUPPLIES

- Toyota Genuine ATF WS or DEXRON®III (DEXRON®II) – As needed
- Hypoid gear oil API GL-5 SAE 75W-90 – 1.5 liter (**4wd Only**)
- R134a refrigerant – As needed
- Toyota DOT 3 brake fluid – 3 pints
- Toyota long life coolant – 2 gallons
- Paint Marker
- MP Grease

### C. PARTS

To assist dealers in determining the correct part number(s) to order, a website has been set up to look up part numbers by VIN. Please go to <http://toyota-frame-parts-lookup.imagespm.info> select the appropriate campaign/vehicle, enter the VIN, and the correct part numbers to order will be displayed. **The website is for part(s) application reference only and won't order the parts, confirm campaign completion status, or confirm campaign applicability.**

- The parts will need to be ordered through the Dealer Daily Parts System.
- ETAs for the parts will be available via the normal system.
- Frame ETAs will be made available on the Dealer Daily website, in the MAC reference area.

**Note: When first logging in; enter your dealer code and the default password; XXXXX. Upon logging in the website will ask for you to reset the password and provide an email address.**

An illustration of the parts replaced and their location(s) have been provided. Please reference the **"Illustration Name"** and **"Page"** columns in the parts tables below.

#### Individual Parts:

Part Number	Part Description	Quantity	Illustration Name	Page
04001-76104	(RCB 2WD 2TR 5MT or 4AT 05-08MY)	1	Frame	8
04001-76204	(ACB 2WD 2TR 5MT or 4AT 05-08MY)	1	Frame	8
04001-76304	(ACB 2WD 1GR 6MT 05-08MY)	1	Frame	8
04001-76404	(RCB 4WD 2TR 5MT 05-08MY)	1	Frame	8
04001-76504	(ACB 4WD 2TR 5MT 05-08MY)	1	Frame	8
04001-76604	(ACB 4WD 1GR 6MT or 5AT 05-08MY)	1	Frame	8
04001-76704	(DCB 4WD 1GR 6MT or 5AT 05-08MY)	1	Frame	8
04001-77604	(RCB Prerunner 2WD 2TR 5MT 05-08MY)	1	Frame	8
04001-76904	(ACB 2WD 2TR 5MT 05-08MY)	1	Frame	8
04001-77104	(ACB 2WD 1GR 5AT 05-08MY)	1	Frame	8
04001-77204	(ACB 2WD 1GR 6MT 05-08MY)	1	Frame	8
04001-77304	(DCB 2WD 1GR 5AT 05-08MY)	1	Frame	8
04001-77404	(DCB 2WD 1GR 5AT Super Long 05-08MY)	1	Frame	8
04001-77504	(DCB 4WD 1GR 5AT super long 05-08MY)	1	Frame	8
04006-63104	(RCB 2WD 2TR 5MT or 4AT 09 -10 MY)	1	Frame	8
04006-63204	(ACB 2WD 2TR 5MT or 4AT 09 -10 MY)	1	Frame	8
04006-63304	(ACB 2WD 1GR 6MT 09 -10 MY)	1	Frame	8
04006-63404	(RCB 4WD 2TR 5MT 09 -10 MY)	1	Frame	8
04006-63504	(ACB 4WD 2TR 5MT 09 -10 MY)	1	Frame	8
04006-63604	(ACB 4WD 1GR 6MT or 5AT 09 -10 MY)	1	Frame	8
04006-63704	(DCB 4WD 1GR 6MT or 5AT 09 -10 MY)	1	Frame	8
04006-63804	(RCB Prerunner 2WD 2TR 5MT 09-10 MY)	1	Frame	8
04006-63904	(ACB 2WD 2TR 5MT 09-10 MY)	1	Frame	8
04006-64104	(ACB 2WD 1GR 5AT 09-10 MY)	1	Frame	8
04006-64204	(ACB 2WD 1GR 6MT 09-10 MY)	1	Frame	8
04006-64304	(DCB 2WD 1GR 5AT 09-10 MY)	1	Frame	8
04006-64404	(DCB 2WD 1GR 5AT Super Long 09-10 MY)	1	Frame	8
04006-64504	(DCB 4WD 1GR 5AT Super Long 09-10 MY)	1	Frame	8

**Individual Parts (Continued):**

Part Number	Part Description	Quantity	Illustration Name	Page
43425-04040	Ring, Drive Shaft Snap	2	Front Suspension	10
47323-04160	Tube, RR Brake, No.3	1	Brake Tubes	12-14
47324-04120	Tube, RR Brake, No.4	1	Brake Tubes	12-14
47325-04160	Tube, RR Brake, No.5 (05-08MY)	1	Brake Tubes	12,15
47325-04170	Tube, RR Brake, No.5 (05-08MY)	1	Brake Tubes	13,16
47325-04180	Tube, RR Brake, No.5 (05-08MY)	1	Brake Tubes	14,17
47325-04190	Tube, RR Brake, No.5 (09-10MY)	1	Brake Tubes	
47325-04200	Tube, RR Brake, No.5 (09-10MY)	1	Brake Tubes	
47325-04210	Tube, RR Brake, No.5 (09-10MY)	1	Brake Tubes	
47326-04130	Tube, RR Brake, No.6 (05-08MY)	1	Brake Tubes	12,15
47326-04140	Tube, RR Brake, No.6 (05-08MY)	1	Brake Tubes	13,16
47326-04150	Tube, RR Brake, No.6 (05-08MY)	1	Brake Tubes	14,17
47326-04160	Tube, RR Brake, No.6 (09-10MY)	1	Brake Tubes	
47326-04170	Tube, RR Brake, No.6 (09-10MY)	1	Brake Tubes	
47326-04180	Tube, RR Brake, No.6 (09-10MY)	1	Brake Tubes	
48068-04030	Arm Sub-Assy, Suspension LWR RH w/ Bush	1	Front Suspension	9
48068-04040	Arm Sub-Assy, Suspension LWR RH w/ Bush	1	Front Suspension	10
48069-04030	Arm Sub-Assy, Suspension LWR LH w/ Bush	1	Front Suspension	9
48069-04040	Arm Sub-Assy, Suspension LWR LH w/ Bush	1	Front Suspension	10
48210-04370	Spring Assy, RR RH	1	Rear Suspension	11
48210-04380	Spring Assy, RR RH	1	Rear Suspension	11
48210-AD020	Spring Assy, RR RH	1	Rear Suspension	11
48220-04160	Spring Assy, RR LH	1	Rear Suspension	11
48220-04170	Spring Assy, RR LH	1	Rear Suspension	11
48220-AD020	Spring Assy, RR LH	1	Rear Suspension	11
48304-04090	Bumper Sub-Assy, FR Spring	2	Front Suspension	9
48304-AD010	Bumper Sub-Assy, FR Spring	2	Front Suspension	9
89516-04010	Wire, Skid Control Sensor	1	ABS	19
89516-04020	Wire, Skid Control Sensor	1	ABS	19
89516-04040	Wire, Skid Control Sensor	1	ABS	19
89516-04090	Wire, Skid Control Sensor	1	ABS	19
90117-A0001	Bolt, U	4	Rear Suspension	11
90117-A0002	Bolt, U	4	Rear Suspension	11
90117-A0005	Bolt, U	4	Rear Suspension	11
90119-08A91	Bolt, w/ Washer	4	Rear Suspension	11
90119-A0151	Bolt, w/ Washer	2	Propeller Shaft	21
90119-A0161	Bolt, w/ Washer	4	Front Suspension	9
90119-A0169	Bolt, w/ Washer	9	Brake Tubes	12-18
90119-A0193	Bolt, w/ Washer	2	Under Cover	8
90178-A0013	Nut, Flange	4	Front Suspension	9
90179-08241	Nut	4	Fuel Tank	18
90240-08054	Pin, w/ Hole	1	Shift Lever	23
90468-14033	Clip	1	Shift Lever	23
90469-A0004	Clamp	2	Brake Tubes	12,15
90469-A0004	Clamp	3	Brake Tubes	13,16
90469-A0004	Clamp	4	Brake Tubes	14,17
51900-35410	Carrier Assy, Spare Wheel	1	Spare Tire Carrier	8
51900-35420	Carrier Assy, Spare Wheel	1	Spare Tire Carrier	8
5114A-04010	Seal, Frame Side Rail, RH*	1	No Illustration	N/A
5114B-04010	Seal, Frame Side Rail, LH*	1	No Illustration	N/A
90178-A0024	Nut w/Flange*	2	No Illustration	N/A
90119-A0170	Bolt with Washer*	2	No Illustration	N/A

\*Note Frame seal and mounting hardware are only needed for frames that do not come with them previously installed.

**Parts Kits:**

Part Number	Part Description	Quantity		
04001-71104	Parts Kit No.1 – Common Replacement Kit A	1		
<b>The kit listed above includes the following parts:</b>				
Part Number	Part Description	Qty	Illustration Name	Page
77285-35760	Support, Fuel Return & Main Tube	1	Fuel Tubes	18
90179-10201	Nut	4	Engine Mounting	20
90412-10247	Way, 2	2	Brake Tubes	12-17
90910-03001	Bolt, Engine Mount	4	Engine Mounting	20
91671-80814	Bolt, Flange w/ Washer	4	Engine Mounting	20
94622-51400	Washer, Plain	10	Rear Suspension	11

Part Number	Part Description	Quantity		
04001-71204	Parts Kit No.2 – Common Replacement Kit B (2wd Non-PreRunner)	1		
<b>The kit listed above includes the following parts:</b>				
Part Number	Part Description	Qty	Illustration Name	Page
04483-04080	Shackle Kit, RR Spring	2	Rear Suspension	11
17451-0A010	Gasket, Exhaust Pipe	1	Exhaust System	22
47355-04020	Bracket, Flexible Hose, No. 5	1	Brake Tubes	12-17
51719-04010	Holder, Body Support Bracket	2	Cab Mounting	8
90069-08019	Ring, O	1	Radiator	23
90080-10138	Bolt, Flange	2	Rear Suspension	11
90080-11376	Bolt, w/ Washer	2	Fuel Tank	18
90080-11555	Bolt, w/ Washer	2	Power Steering	20
90080-17215	Nut, Flange	6	Front Suspension	9,10
90119-A0169	Bolt, w/ Washer	4	Spare Tire carrier	8
90119-A0192	Bolt, w/ Washer	6	Rear Bumper	23
90171-A0005	Nut, Castle	2	Front Suspension	9-10
90177-A0010	Nut, Lock	2	Rear Suspension	11
90178-A0044	Nut, Flange	6	Front Bumper	23
90178-A0050	Nut, Flange	10	Rear Suspension	11
90210-A0002	Washer, Seal	1	Air Conditioning	23
90210-A0004	Washer, Seal	1	Air Conditioning	23
90412-10248	Way, 2	1	Brake Tubes	12-17
90468-A0007	Clip	4	Brake Tubes	12-18
90949-A1006	Clamp	3	Brake Tubes	12-17

Part Number	Part Description	Quantity		
04006-54104	Parts Kit No.2 – Common Replacement Kit C (4WD and PreRunner)	1		
<b>The kit listed above includes the following parts:</b>				
Part Number	Part Description	Qty	Illustration Name	Page
17451-0A010	Gasket, Exhaust Pipe	1	Exhaust System	22
47355-04020	Bracket, Flexible Hose, No. 5	1	Brake Tubes	12-17
51719-04010	Holder, Body Support Bracket	2	Cab Mounting	8
90069-08019	Ring, O	1	Radiator	23
90080-10138	Bolt, Flange	2	Rear Suspension	11
90080-A0249	Bolt, w/ Washer	2	Fuel Tank	18
90080-11555	Bolt, w/ Washer	2	Power Steering	20
90080-17215	Nut, Flange	6	Front Suspension	9,10
90119-A0169	Bolt, w/ Washer	4	Spare Tire carrier	8
90119-A0192	Bolt, w/ Washer	6	Rear Bumper	23
90171-A0005	Nut, Castle	2	Front Suspension	9-10
90177-A0010	Nut, Lock	2	Rear Suspension	11
90178-A0044	Nut, Flange	6	Front Bumper	23
90178-A0050	Nut, Flange	10	Rear Suspension	11
90210-A0002	Washer, Seal	1	Air Conditioning	23
90210-A0004	Washer, Seal	1	Air Conditioning	23
90412-10248	Way, 2	1	Brake Tubes	12-17
90468-A0007	Clip	4	Brake Tubes	12-18
90949-A1006	Clamp	3	Brake Tubes	12-17

Part Number	Part Description	Quantity		
04001-71304	Parts Kit No.3 – JPN Source Parts kit 1 (4WD 05-08MY)	1		
<b>The kit listed above includes the following parts:</b>				
Part Number	Part Description	Qty	Illustration Name	Page
12157-10010	Gasket, Drain Plug	1	Front Differential	20
43514-28010	Cap, FR Hub Grease	2	Front Suspension	10
90311-47027	Seal, Type T Oil	1	Front Differential	20
90311-47013	Seal, Type T Oil	1	Front Differential	20
90430-24003	Gasket	1	Front Differential	20
95381-04045	Pin, Cotter	2	Front Suspension	10

Part Number	Part Description	Quantity		
04006-46104	Parts Kit No.3 – JPN Source Parts kit 4 (4WD 09-10MY)	1		
<b>The kit listed above includes the following parts:</b>				
Part Number	Part Description	Qty	Illustration Name	Page
12157-10010	Gasket, Drain Plug	1	Front Differential	20
43514-28010	Cap, FR Hub Grease	2	Front Suspension	10
90311-47026	Seal, Type T Oil	1	Front Differential	20
90311-47027	Seal, Type T Oil	1	Front Differential	20
90430-24003	Gasket	1	Front Differential	20
95381-04045	Pin, Cotter	2	Front Suspension	10

Part Number	Part Description	Quantity		
04001-71404	Parts Kit No.4 – JPN Source Parts kit 2	1		
<b>The kit listed above includes the following parts:</b>				
Part Number	Part Description	Qty	Illustration Name	Page
48190-25010	Cam Assy, Camber Adjust	4	Front Suspension	9
48198-25010	Cam, Camber Adjust, No. 2	4	Front Suspension	9
95381-03025	Pin, Cotter	2	Power Steering	20
95381-03230	Pin, Cotter	2	Front Suspension	9

Part Number	Part Description	Quantity		
04001-71504	Parts Kit No.5 – JPN Source Parts kit 3	1		
<b>The kit listed above includes the following parts:</b>				
Part Number	Part Description	Qty	Illustration Name	Page
48190-60020	Cam Assy, Camber Adjust	2	Front Suspension	10
48198-60011	Cam, Camber Adjust, No. 2	2	Front Suspension	10
48409-60020	Cam Assy, Camber Adjust	2	Front Suspension	10
48452-35020	Plate, Toe Adjust, No. 2	2	Front Suspension	10
95381-03225	Pin, Cotter	2	Power Steering	20
95381-03230	Pin, Cotter	2	Front Suspension	10

Part Number	Part Description	Quantity		
04001-71604	Parts Kit No.6 – USA Source Parts kit 1 (1GR)	1		
<b>The kit listed above includes the following parts:</b>				
Part Number	Part Description	Qty	Illustration Name	Page
17176-0P010	Gasket, Air Surge Tank to INT Manifold	1	Exhaust System	22
90080-10291	Bolt	2	Exhaust System	22
90080-11180	Bolt, w/ Washer	2	Exhaust System	22
90080-17187	Nut, Lock	4	Exhaust System	22
90080-43036	Gasket, Exhaust Pipe	2	Exhaust System	22
90126-A0011	Stud, Hex Lobular	4	Exhaust System	22

Part Number	Part Description	Quantity
04001-71704	Parts Kit No.7 – USA Source Parts kit 2 (2TR)	1

**The kit listed above includes the following parts:**

Part Number	Part Description	Qty	Illustration Name	Page
90080-43033	Gasket, Exhaust Pipe	1	Exhaust System	22
90080-10064	Bolt, Flange	2	Exhaust System	22
90080-10291	Bolt	2	Exhaust System	22
90177-A0004	Nut, Lock	2	Exhaust System	22

Part Number	Part Description	Quantity
04001-71804	Parts Kit No.8 – USA Source Parts kit 3	1

**The kit listed above includes the following parts:**

Part Number	Part Description	Qty	Illustration Name	Page
48304-04100	Bumper Sub-Assy, FR Spring	2	Front Suspension	10
75395-35070	Clip, Outside Molding, No. 1	3	Molding	23
75396-35020	Clip, Outside Molding, No. 2	7	Molding	23
90080-11373	Bolt, w/ Washer	8	Under Cover	8
90119-A0166	Bolt, w/ Washer	2	Front Suspension	10
90119-A0192	Bolt, w/ Washer	2	Under Cover	8
90189-A0002	Grommet, Screw	8	Rear Wheel House Liner	24
90189-A0002	Grommet, Screw	2	Molding	23

Part Number	Part Description	Quantity
04001-71904	Parts Kit No.9 – USA Source Parts kit 4	1

**The kit listed above includes the following parts:**

Part Number	Part Description	Qty	Illustration Name	Page
75395-04010	Clip, Outside Molding, No. 1	4	Molding	24
75395-35070	Clip, Outside Molding, No. 1	4	Molding	24
75396-04010	Clip, Outside Molding, No. 2	14	Molding	24
75396-35020	Clip, Outside Molding, No. 2	2	Molding	24
90189-A0002	Grommet, Screw	6	Rear Wheel House Liner	24
90189-A0002	Grommet, Screw	2	Molding	24

Part Number	Part Description	Quantity
04001-72104	Parts Kit No.10 – Brake Tube kit 1 (without VSC)	1

**The kit listed above includes the following parts:**

Part Number	Part Description	Qty	Illustration Name	Page
47313-04190	Tube, FR Brake, No.3	1	Brake Tubes	12-14
47315-04160	Tube, FR Brake, No.5	1	Brake Tubes	12-14

Part Number	Part Description	Quantity
04001-72204	Parts Kit No.11 – Brake Tube kit 2 (with VSC)	1

**The kit listed above includes the following parts:**

Part Number	Part Description	Qty	Illustration Name	Page
47313-04200	Tube, FR Brake, No.3	1	Brake Tubes	15-17
47315-04170	Tube, FR Brake, No.5	1	Brake Tubes	15-17
47323-04170	Tube, RR Brake, No.3	1	Brake Tubes	15-17
47324-04130	Tube, RR Brake, No.4	1	Brake Tubes	15-17

Part Number	Part Description	Quantity
04001-72304	Parts Kit No.12 – Brake Tube kit 3 (for 2WD)	1

**The kit listed above includes the following parts:**

Part Number	Part Description	Qty	Illustration Name	Page
47314-04140	Tube, FR Brake, No.4	1	Brake Tubes	12,13,15,16
47316-04140	Tube, FR Brake, No.6	1	Brake Tubes	12,13,15,16
47351-04030	Bracket, Flexible Hose, RH	1	Brake Tubes	18
47352-04030	Bracket, Flexible Hose, LH	1	Brake Tubes	18

Part Number	Part Description	Quantity
04001-72404	Parts Kit No.13 – Brake Tube kit 4 (for 4WD, PRE-RUNNER)	1

**The kit listed above includes the following parts:**

Part Number	Part Description	Qty	Illustration Name	Page
47314-04150	Tube, FR Brake, No.4	1	Brake Tubes	12-17
47316-04150	Tube, FR Brake, No.6	1	Brake Tubes	12-17
47353-04010	Bracket, Flexible Hose, No. 3	1	Brake Tubes	18
47354-04010	Bracket, Flexible Hose, No. 4	1	Brake Tubes	18
90119-A0169	Bolt, w/ Washer	7	Brake Tubes	12-18

Part Number	Part Description	Quantity
04007-18135	Plug Hole Kit 4x4 and PreRunner	1

**The kit listed above includes the following parts:**

Part Number	Part Description	Qty	Illustration Name	Page
90950-01983	PLUG,HOLE	4		
90950-01984	PLUG,HOLE	2		
90950-01987	PLUG,HOLE	8		
90950-01989	PLUG,HOLE	4		
90950-01991	PLUG, HOLE	4		
90950-01990	PLUG, HOLE	4		
90950-01992	PLUG, HOLE	2		
90950-01A24	PLUG, HOLE	2		
90950-01931	PLUG, HOLE	1		
90950-01631	PLUG, HOLE	4		
90333-20001	PLUG, HOLE	10		
90333-30002	PLUG, HOLE	28		

Part Number	Part Description	Quantity
04007-18235	Plug Hole Kit 4x2	1

**The kit listed above includes the following parts:**

Part Number	Part Description	Qty	Illustration Name	Page
90950-01983	PLUG, HOLE	4		
90950-01984	PLUG, HOLE	2		
90950-01A09	PLUG, HOLE	2		
90950-01987	PLUG, HOLE	6		
90950-01989	PLUG, HOLE	4		
90950-01991	PLUG, HOLE	4		
90950-01990	PLUG, HOLE	4		
90950-01992	PLUG, HOLE	2		
90950-01A11	PLUG, HOLE	2		
90950-01A24	PLUG, HOLE	2		
90950-01931	PLUG, HOLE	1		
90950-01631	PLUG, HOLE	4		
90333-20001	PLUG, HOLE	2		
90333-30002	PLUG, HOLE	36		

### D. PARTS ILLUSTRATION

#### Frame

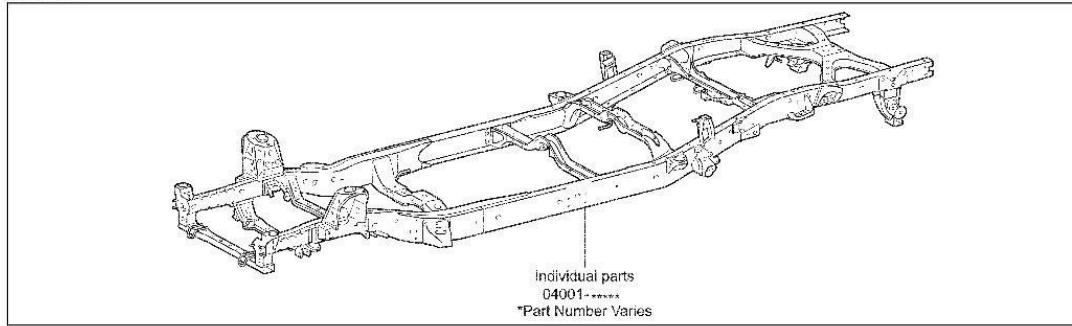

#### Cab Mounting

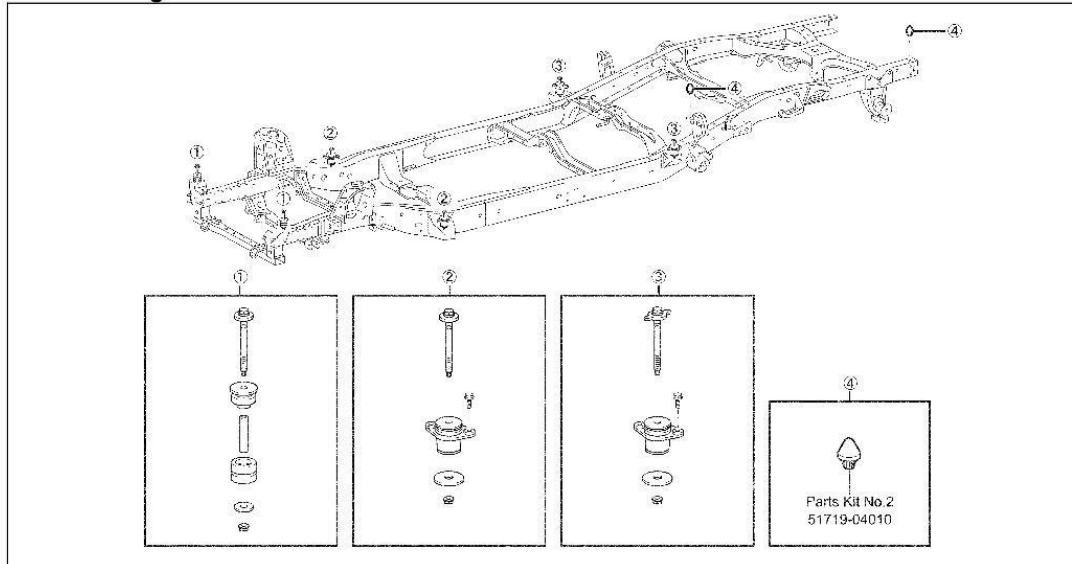

#### Under Cover

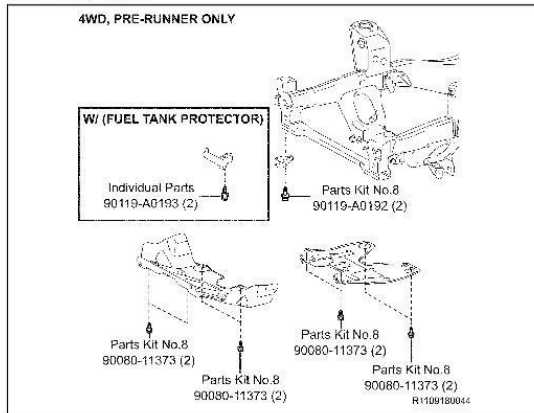

#### Spare Tire Carrier

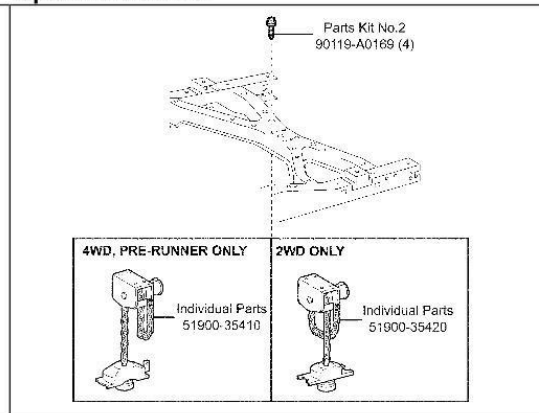

### Front Suspension

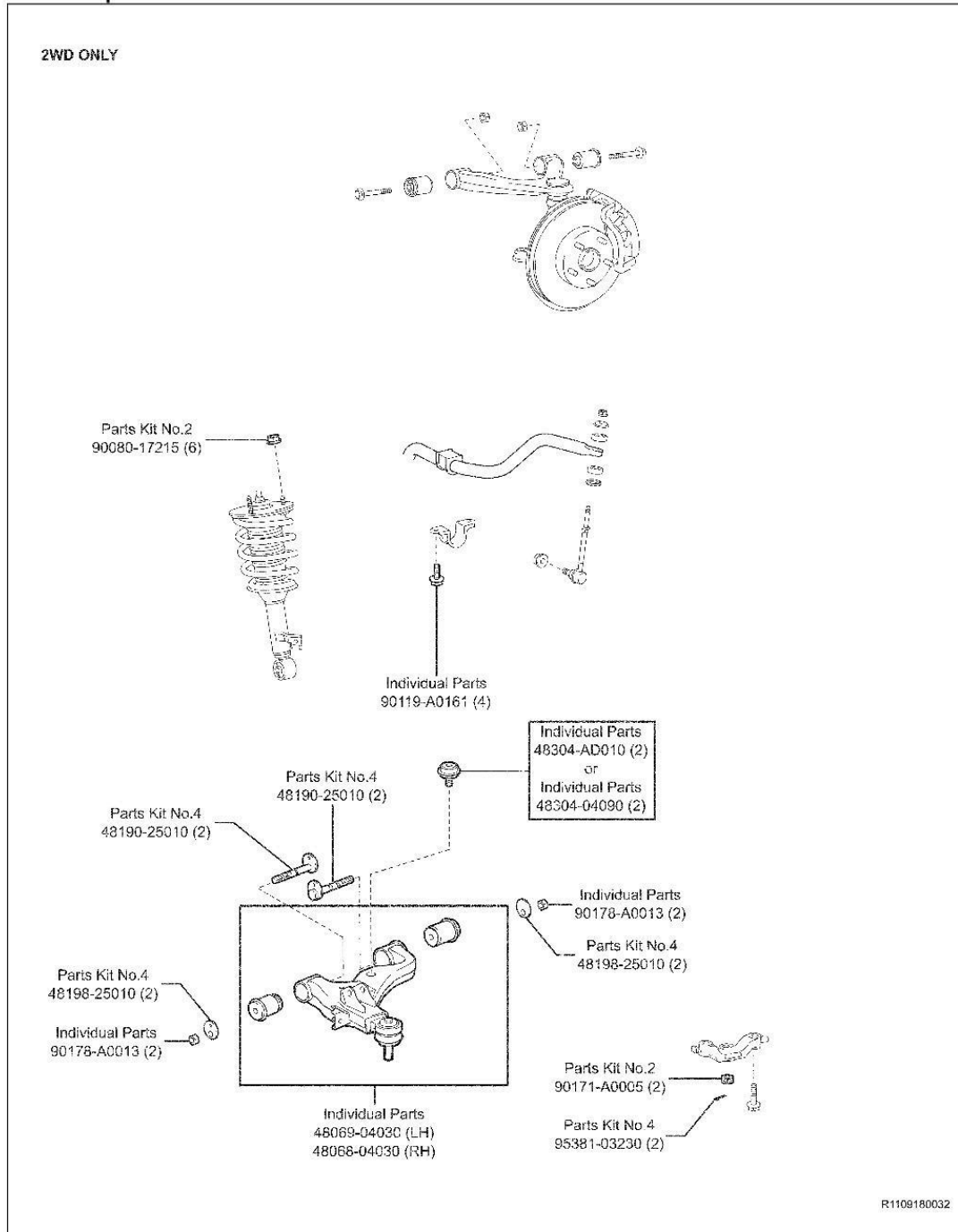

### Front Suspension Continued...

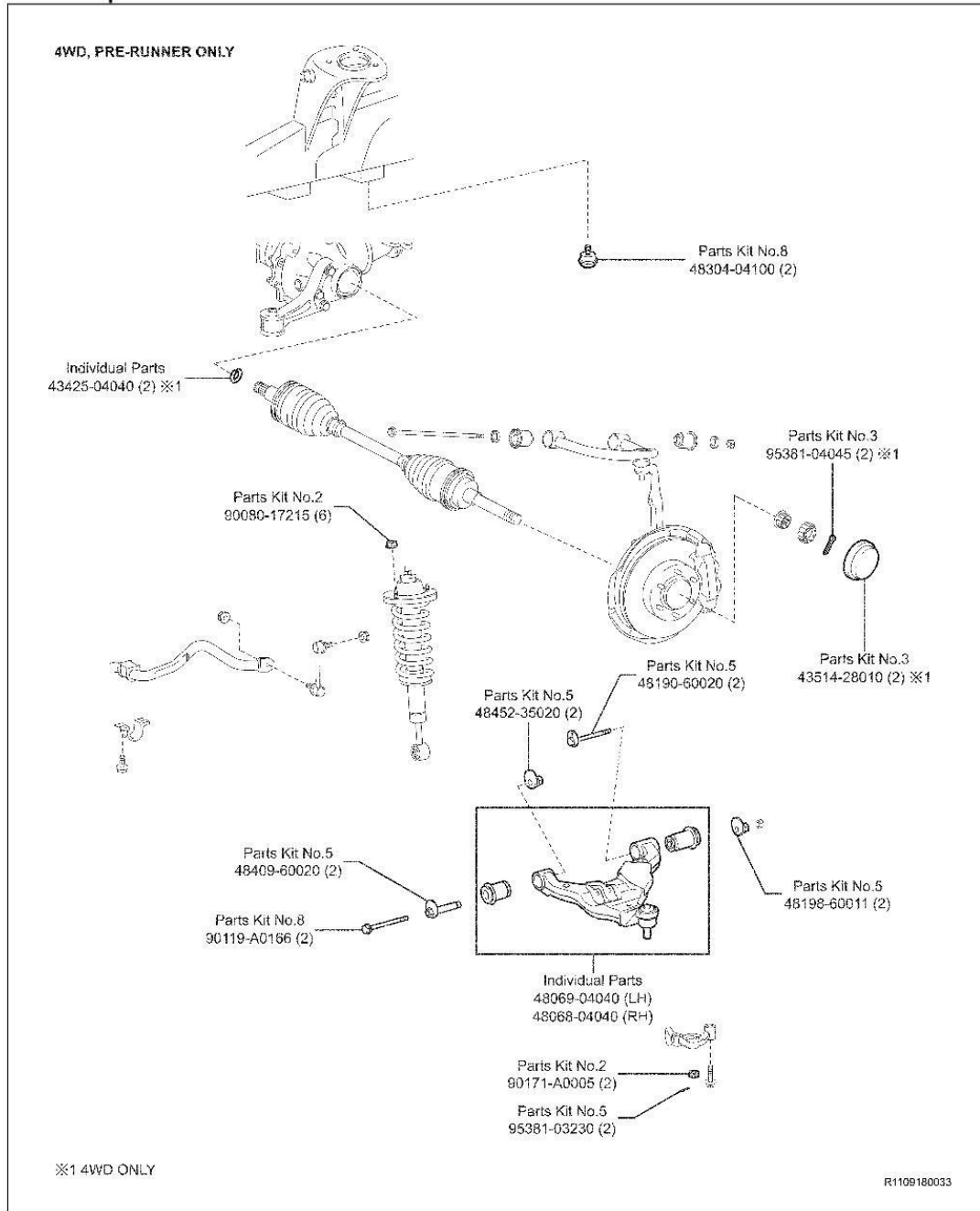

### Rear Suspension

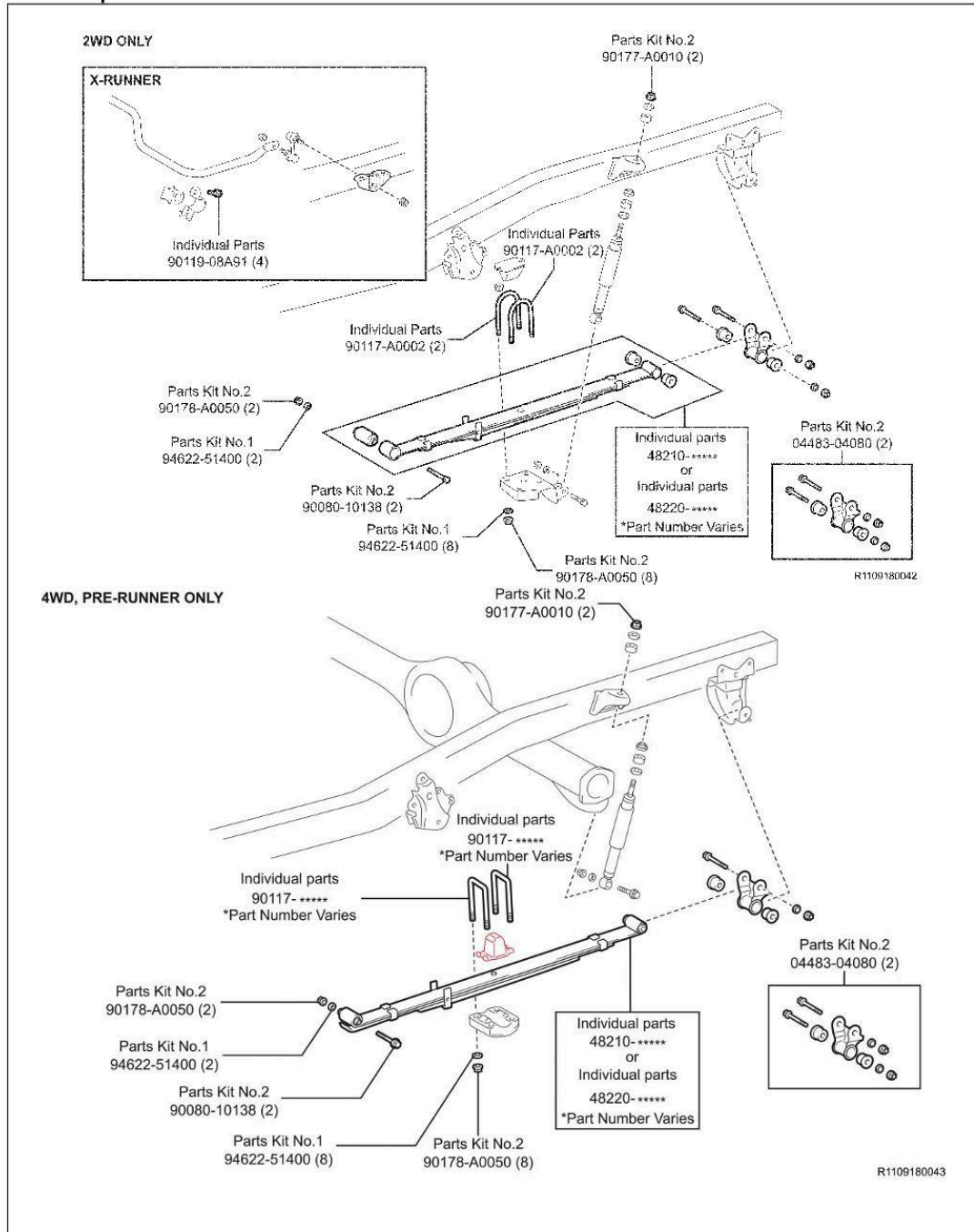

### Brake Tubes

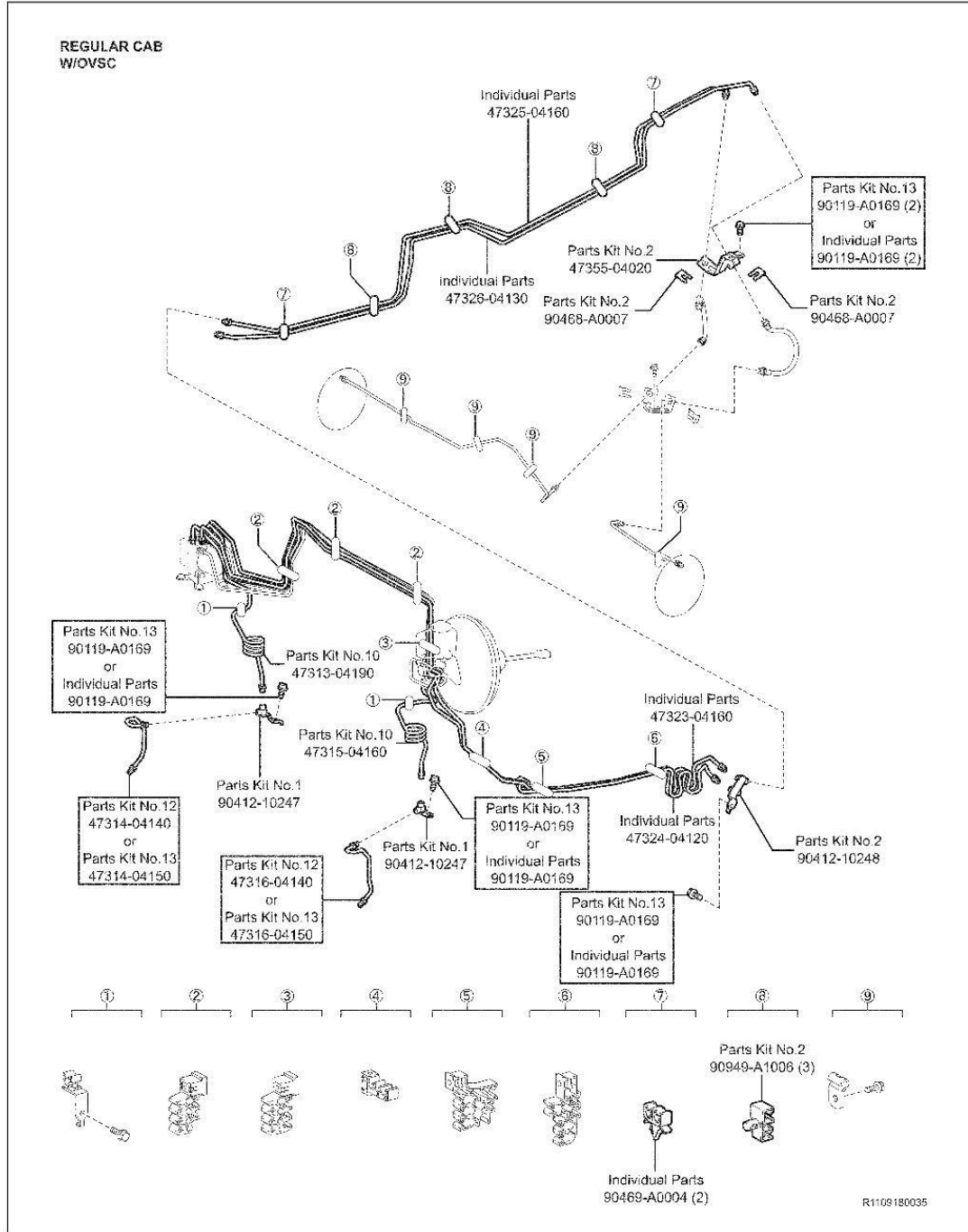

Brake Tubes Continued...

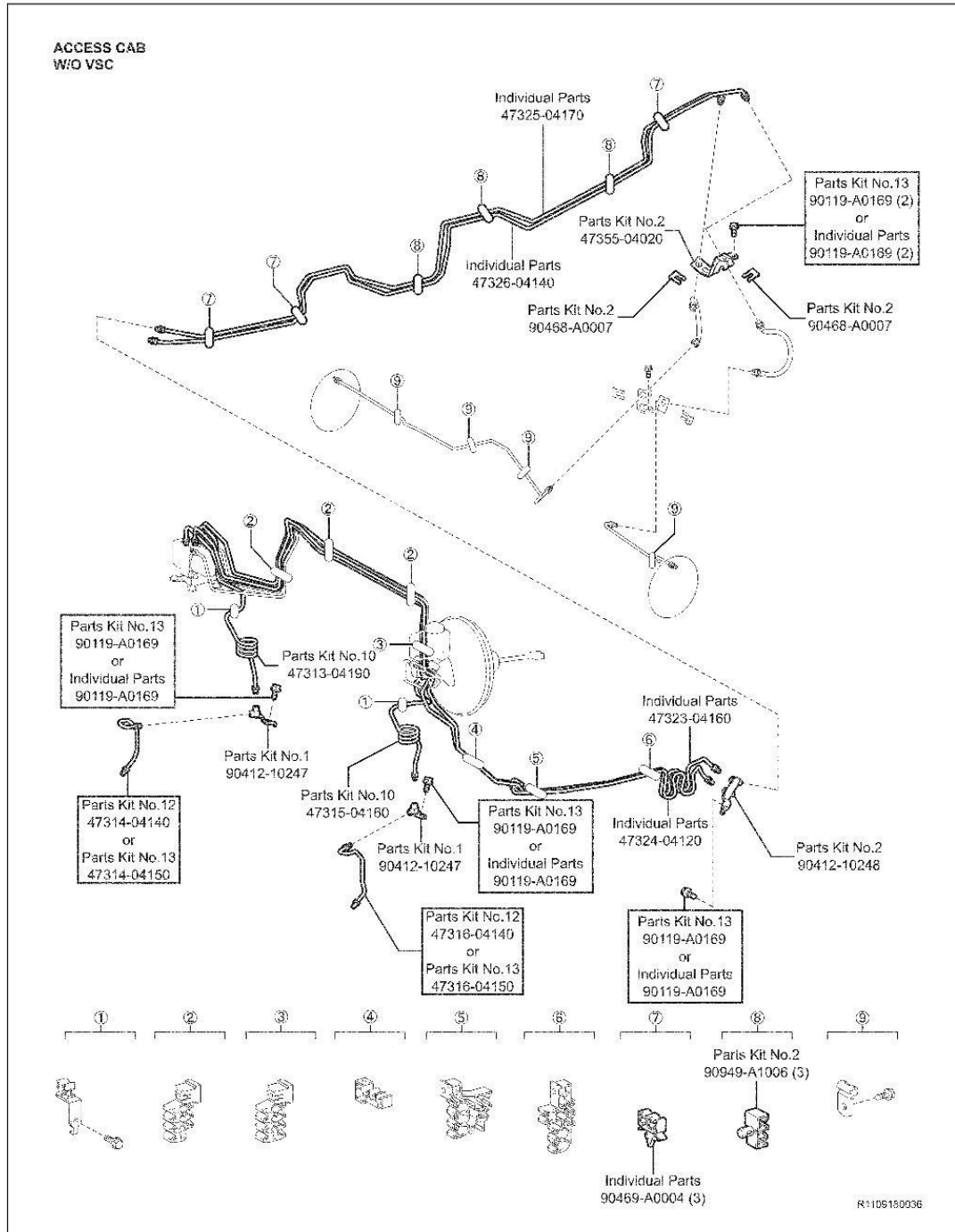

**Brake Tubes Continued...**

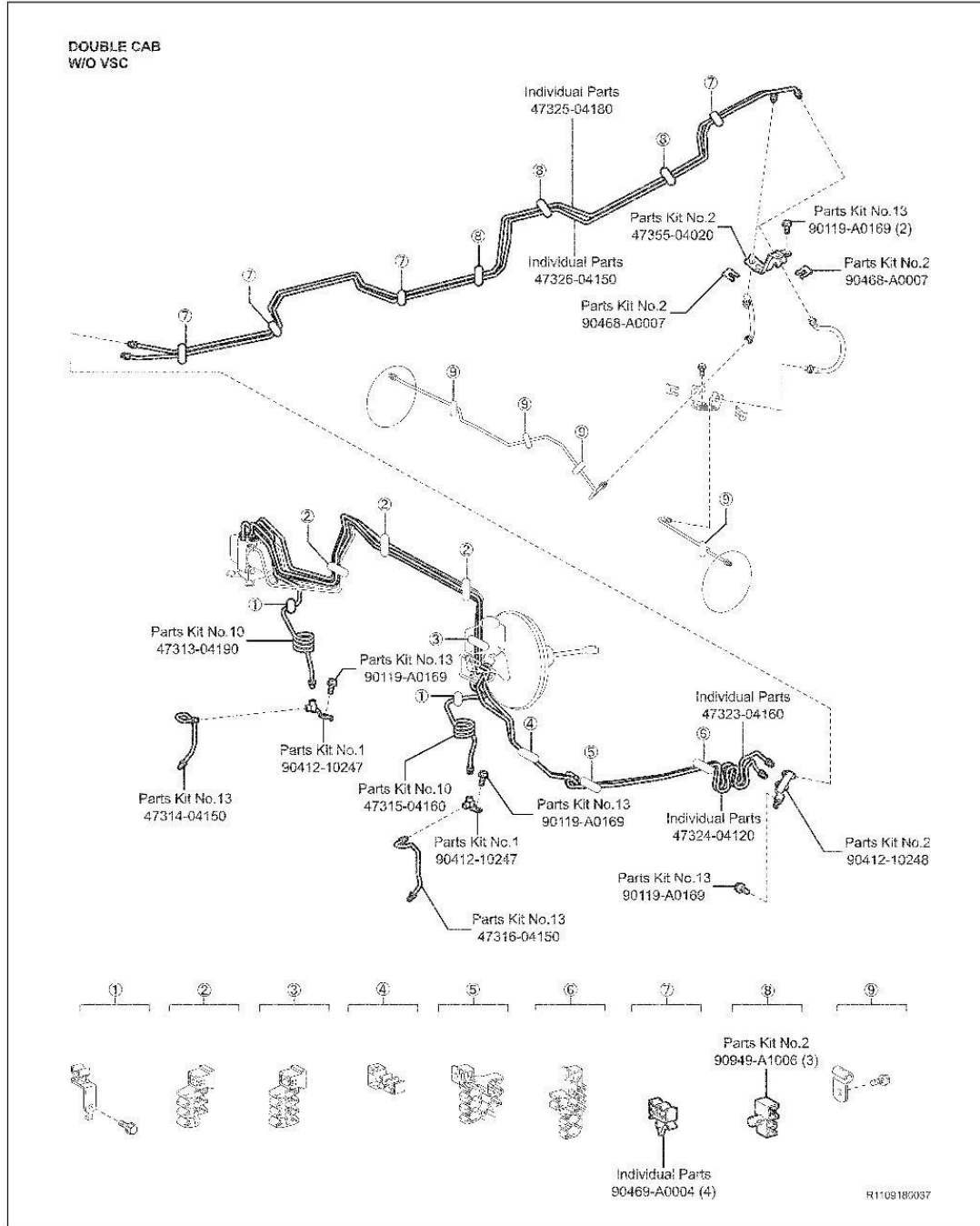

**Brake Tubes Continued...**

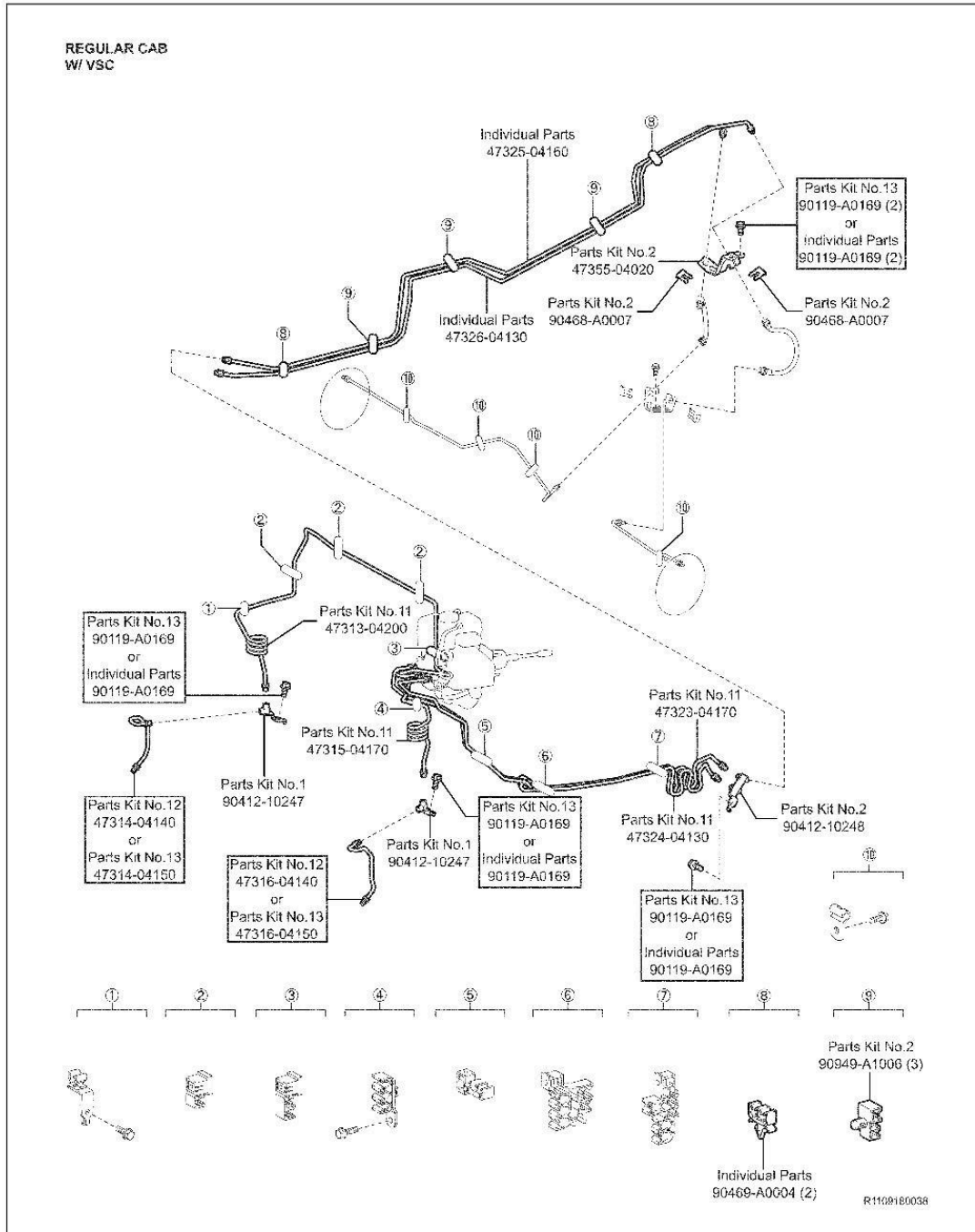

Brake Tubes Continued...

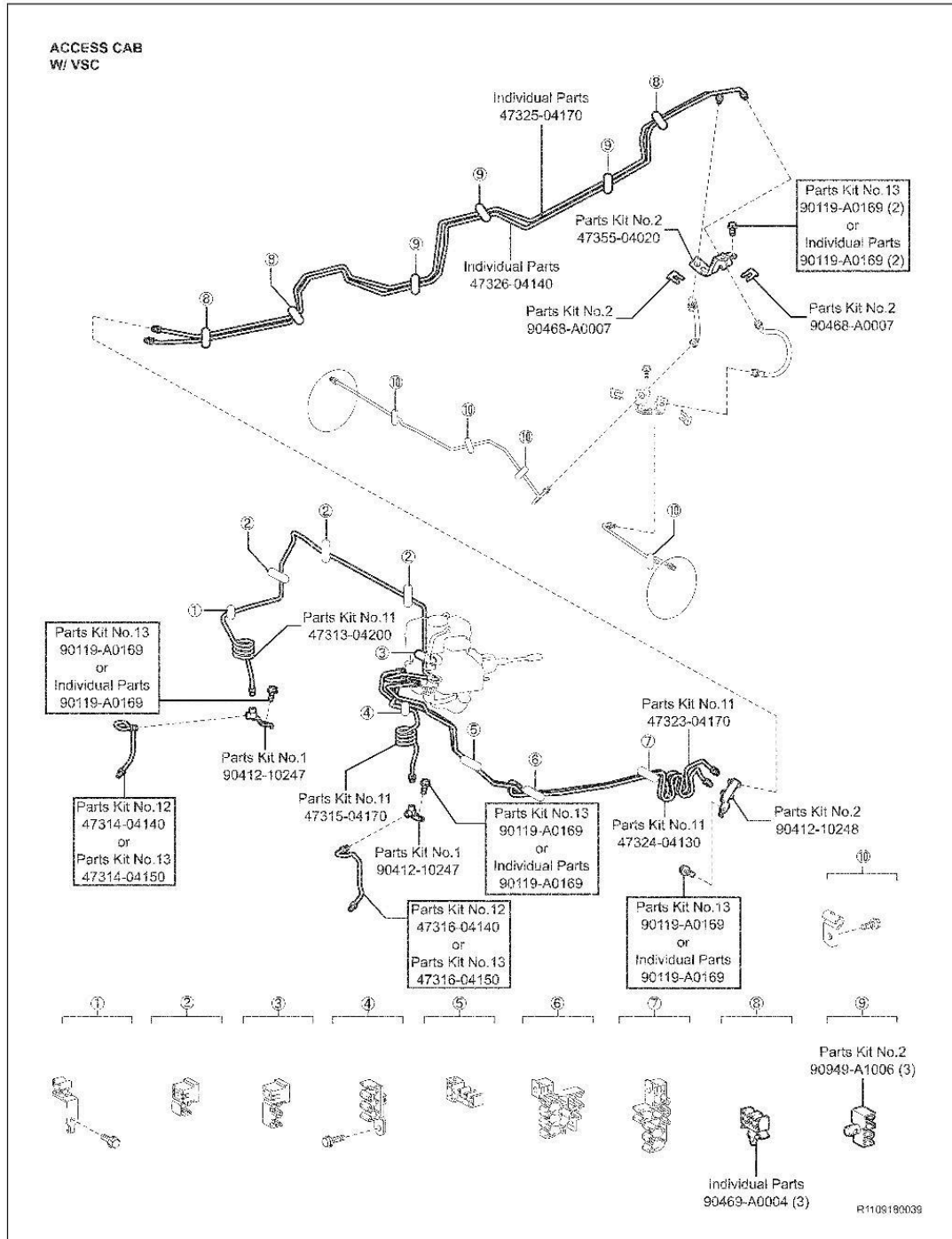

**Brake Tubes Continued...**

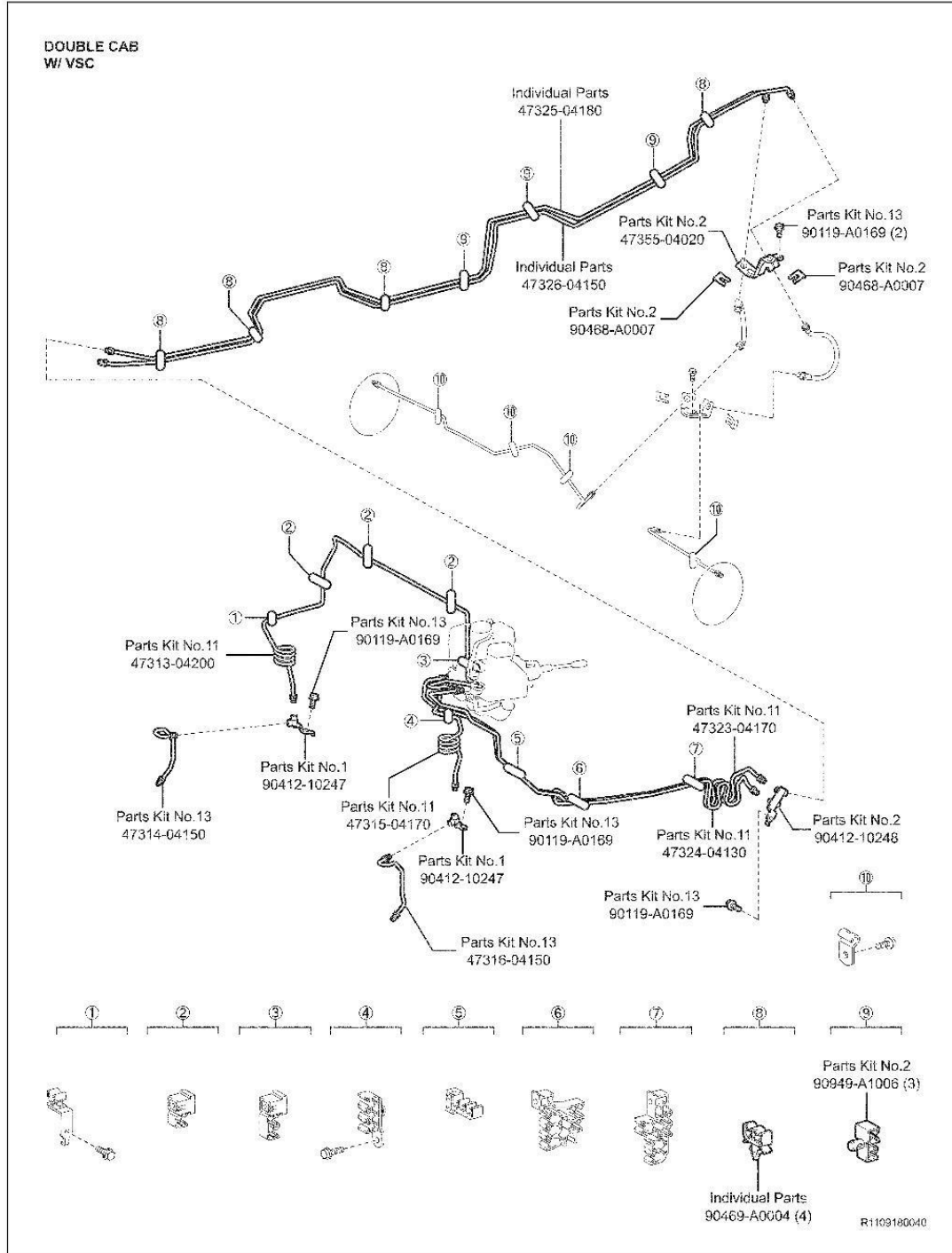

### Brake Tubes Continued...

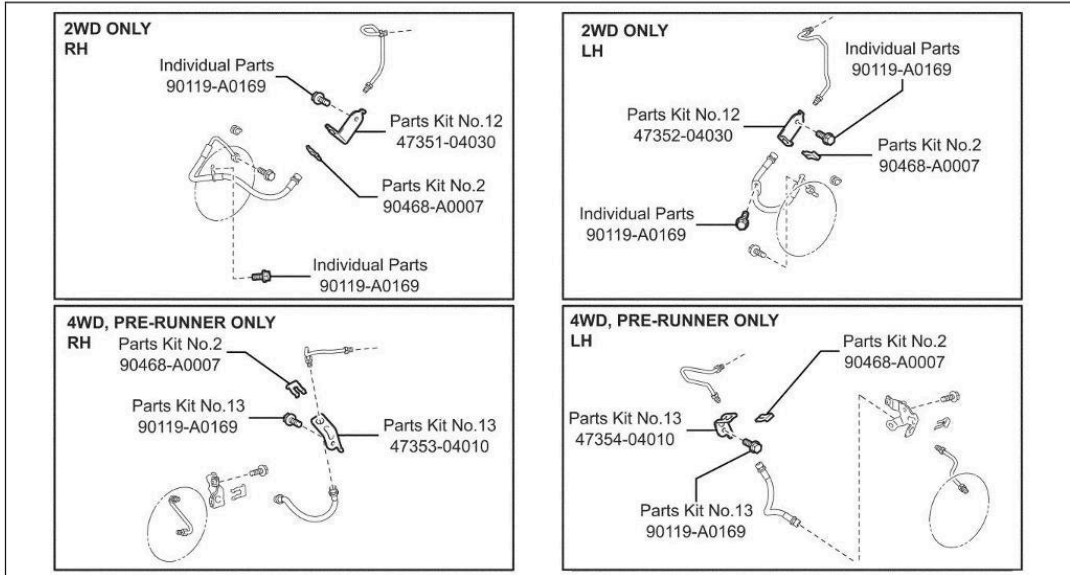

### Fuel Tank

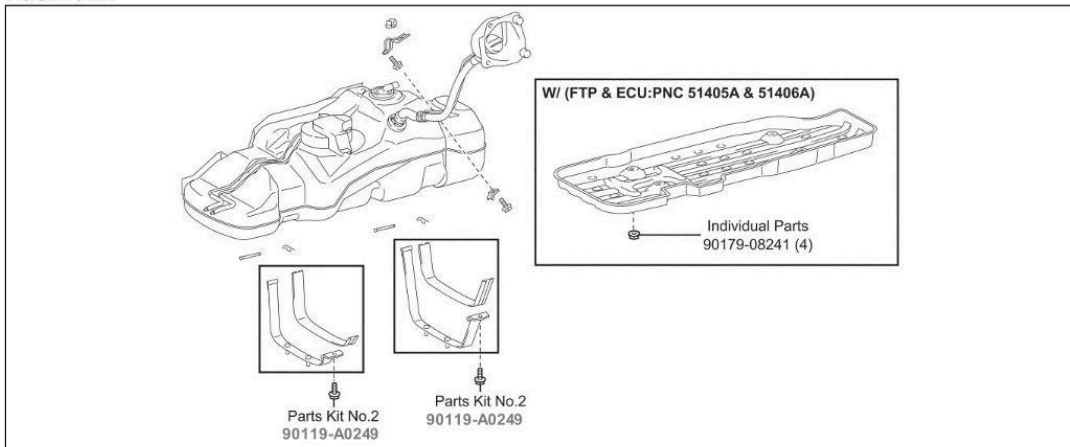

### Fuel Tubes

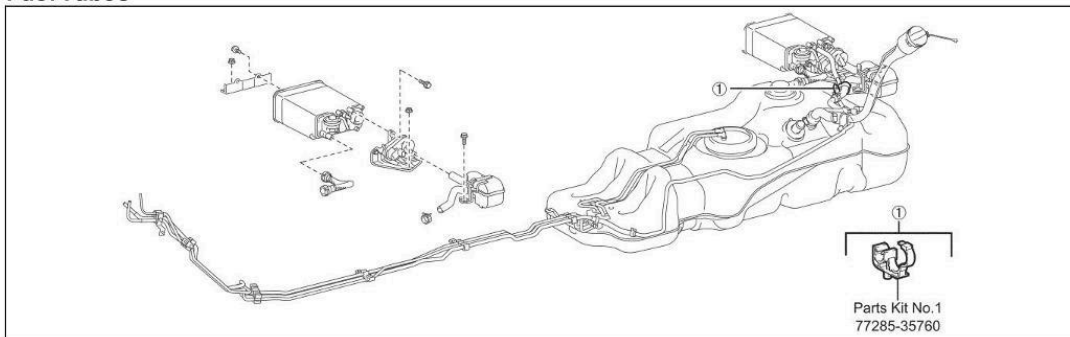

**ABS**

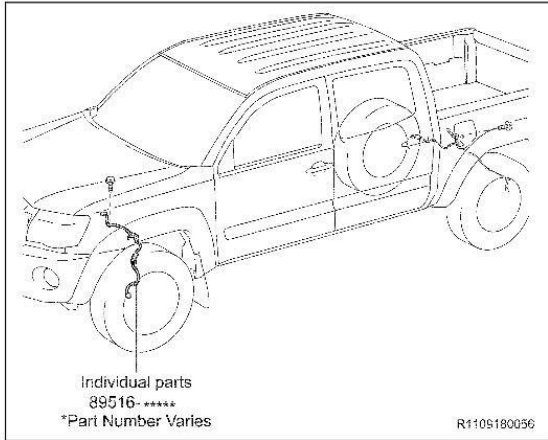

**Wire Harness Clamps**

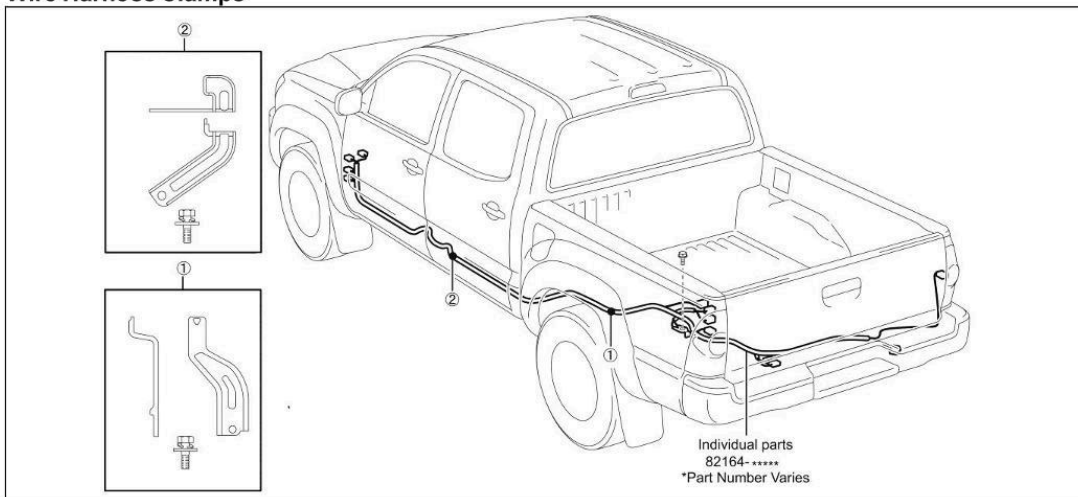

### Power Steering

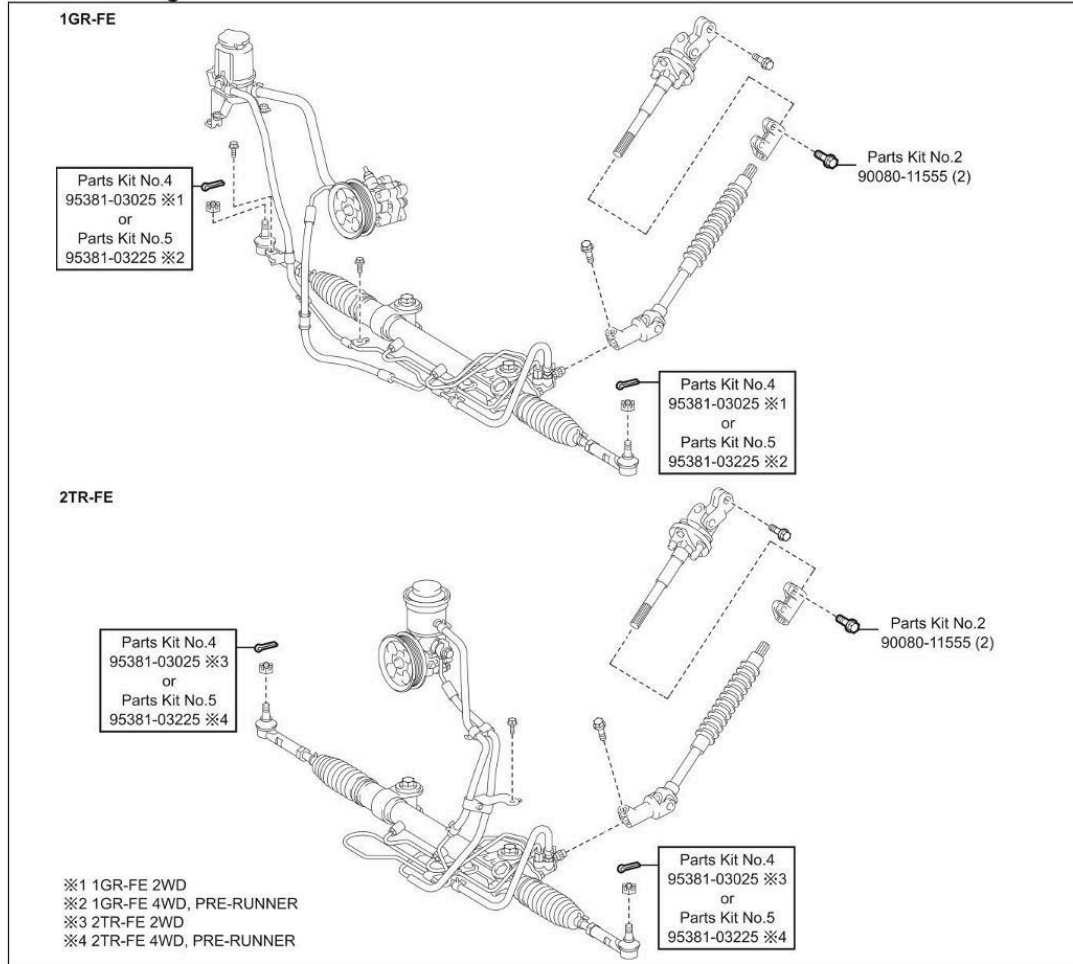

### Front Differential

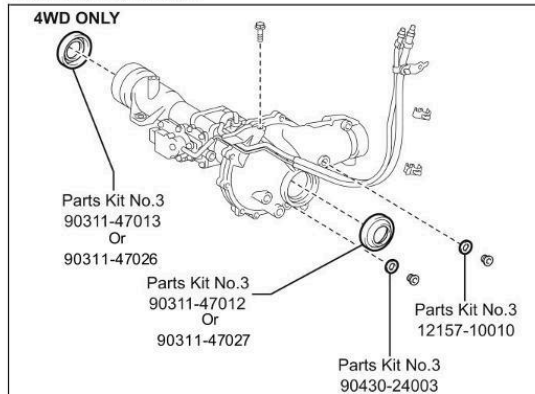

### Engine Mounting

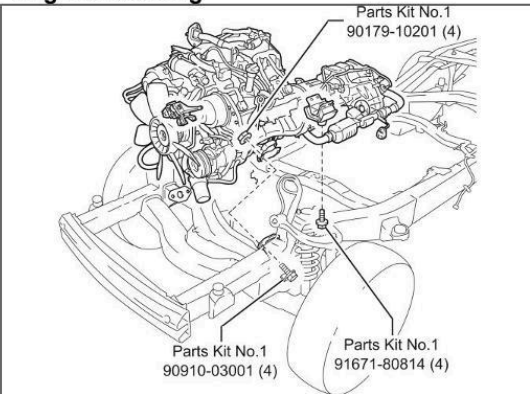

### Propeller Shaft

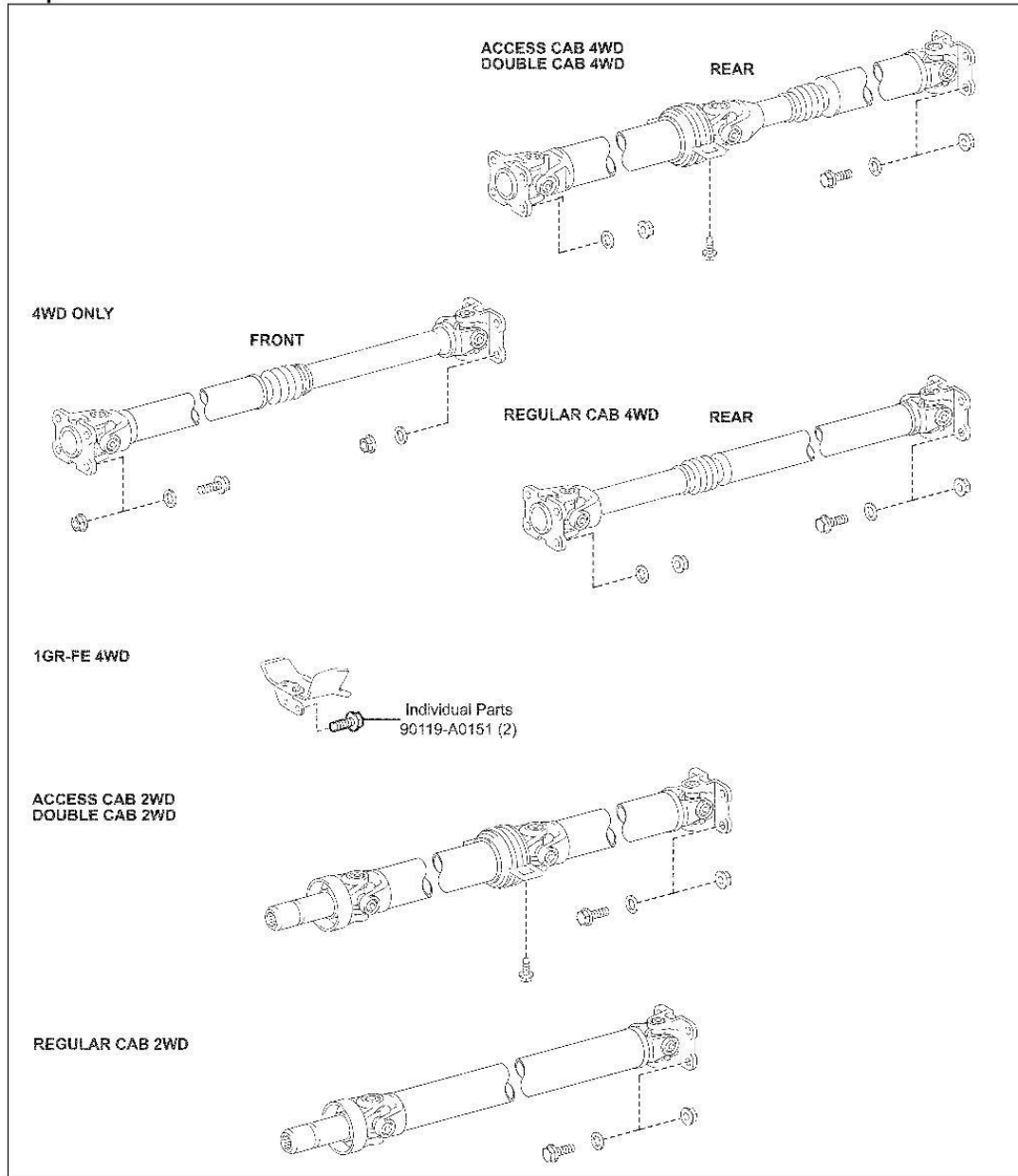

### 1GR-FE Exhaust System

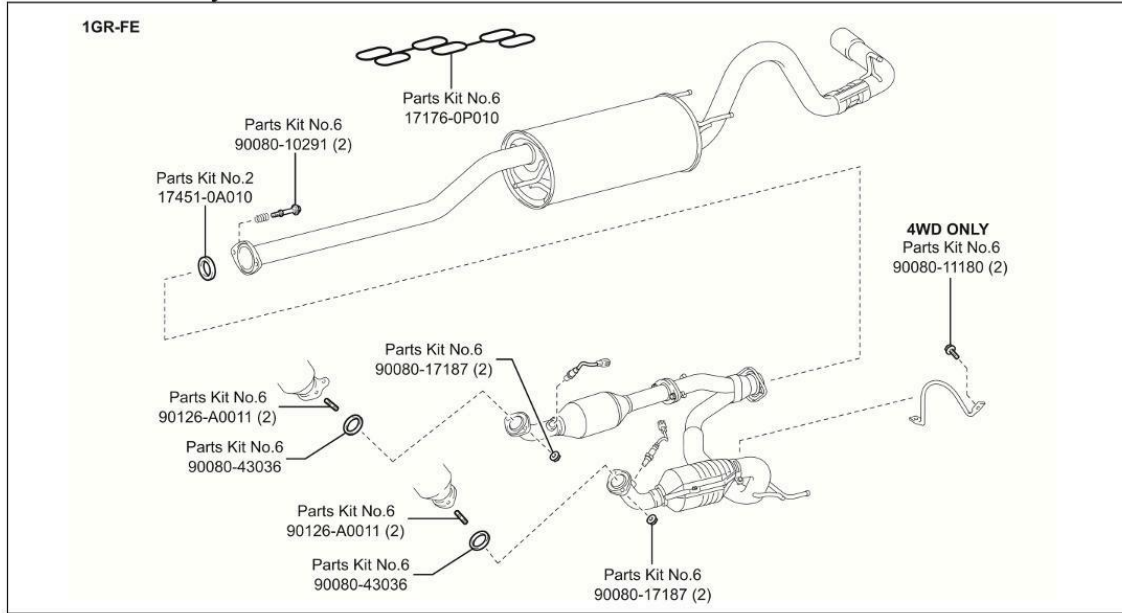

### 2TR-FE Exhaust System

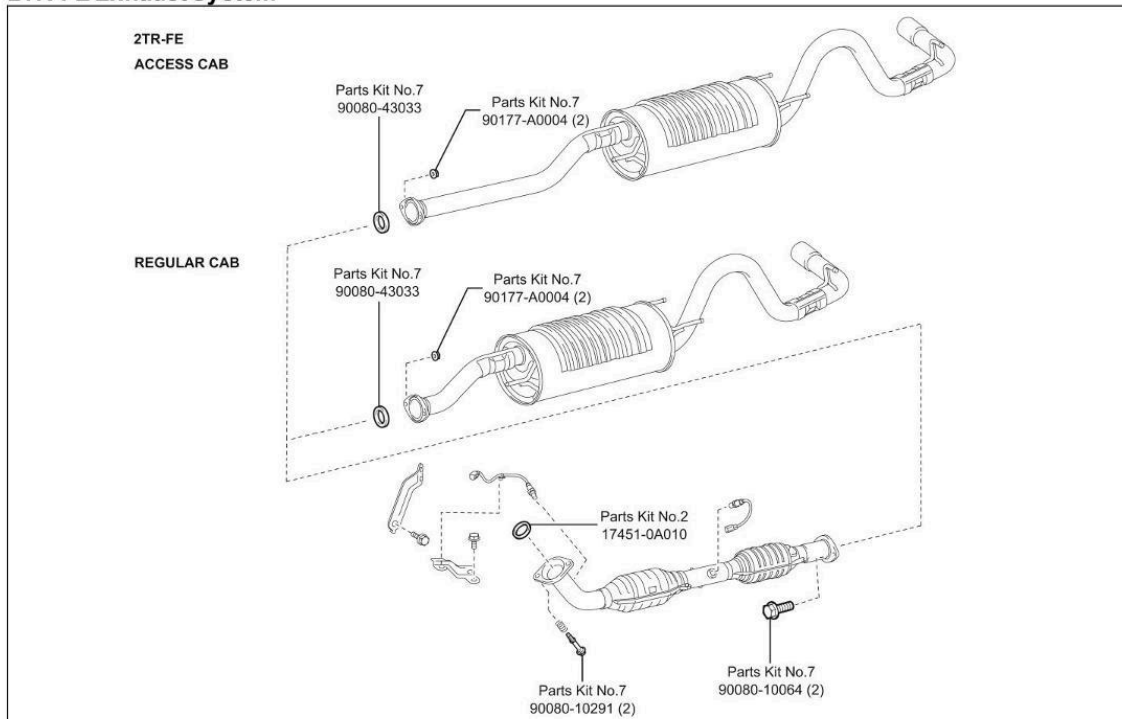

### Shift Lever

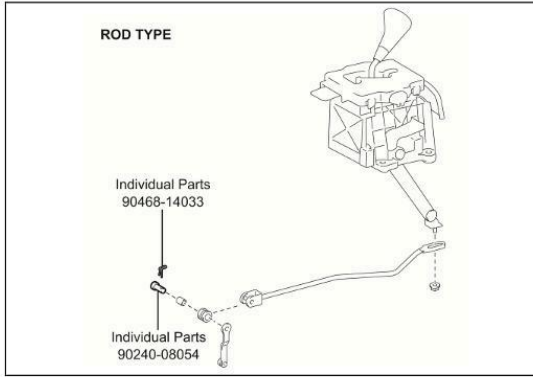

### Radiator

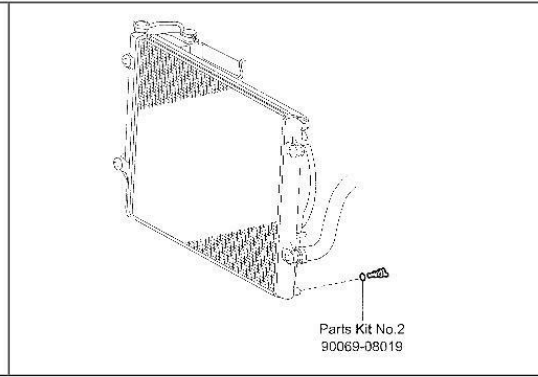

### Air Conditioning

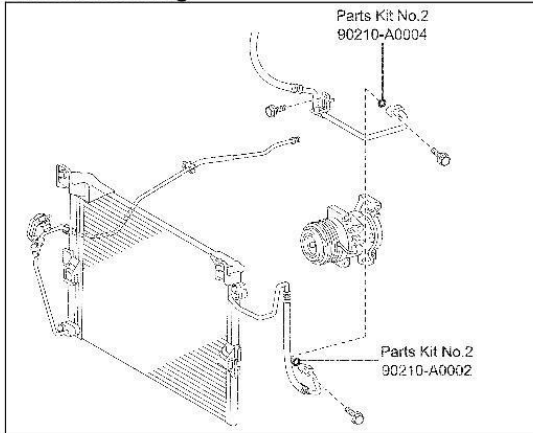

### Front Bumper

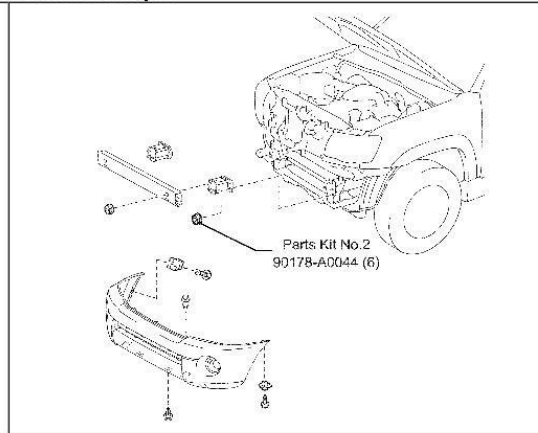

### Rear Bumper

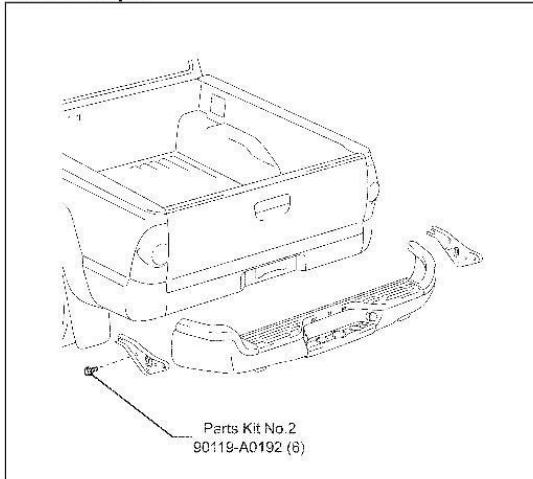

### Molding

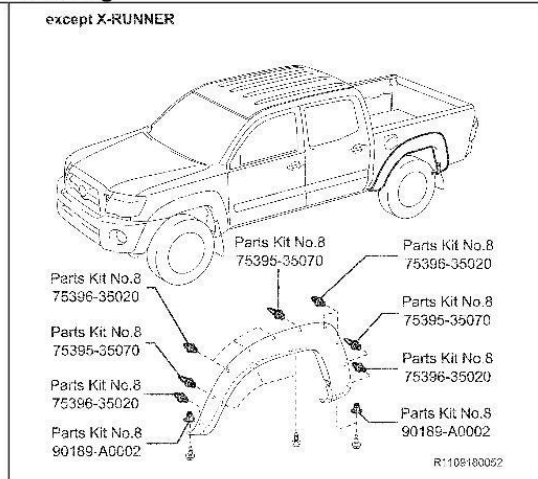

### Rear Wheel House Liner

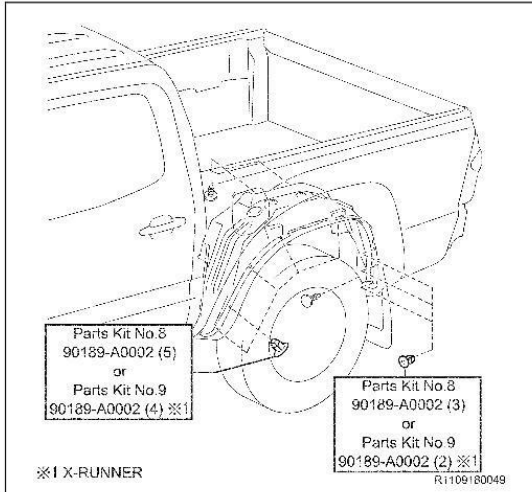

### Molding

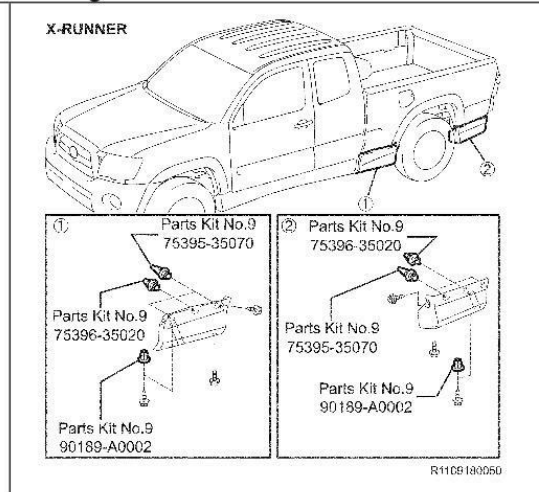

### Moulding Continued...

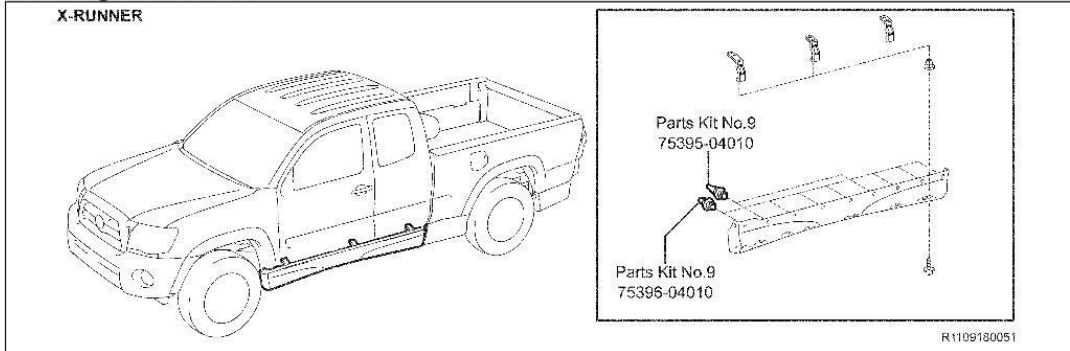

### III. FRAME INSPECTION

#### 1. PERFORM INITIAL PRE-HOIST INSPECTION

1. INSPECT THE FRAME FOR EXCESSIVE FRAME CORROSION THAT COULD AFFECT THE STRUCTURAL INTEGRITY OF THE FRAME

#### 2. FRAME INSPECTION

All frame inspection must be performed using the NEW frame inspection application on TIS. Ensure you inspect the frame and properly document the inspection. Failure to perform this will result in denial of the claim.

#### 1. ACCESS INSPECTION APPLICATION

- a. Run the VIN in TIS and click on the Warranty Tab
- b. Click on the "Frame Inspection" link on TIS

The screenshot shows the TIS interface for a 2005 Toyota Tacoma. The 'Service Campaign' section is expanded, showing a 'Safety Recall E02 - Remedy Notice Certain 2005-2011 Model Year Tacoma Pre-Runner and 4x4 Vehicles Rear Leaf Spring' with a 'Not Completed' status. A red circle highlights the 'Frame Inspection' link in the top right corner of this section.

#### 2. LOG INTO THE INSPECTION APPLICATION

- a. Reenter your TIS password

Frame Inspection

Language:  English  French  Spanish

Re-enter your TIS Password to proceed with the Frame Inspection.

Verify the User ID currently logged into TIS matches the technician's User ID performing the Frame Inspection.

TIS Password



- c. Inspect the frame section and inspect all surfaces of the frame rail and crossmember. Select the photo that best represents the frame condition. If perforation of 10mm or larger is identified select "Peroration of the Frame".

**Note: You must click the bubble next to the image to select the condition.**

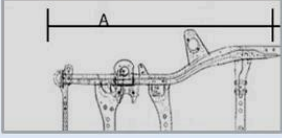





E-Coat Intact



Light to Moderate Surface Rust



Complete Surface Rust with Descaling



Perforation of the Frame

- d. If you selected Perforation of the Frame, the application will request more information about the size of perforation(s) and location.
- e. The section with perforation will split into 2 sub-sections to further identify the perforation location.
- f. Select the size of the perforation in each sub-section.
- g. Upload a photo for each area containing perforation and describe the location in the comments section.

**Note:**

- If both sub-sections have perforation, it will require two pictures to be uploaded.
- If perforation was accidentally selected use the back button to reselect the correct frame condition.

- h. Select Next to move onto the next section.

**Select Perforation Identification - NO CRC Applied**

The frame section has been split into two smaller sections to help clarify to the technical staff where the perforation is located. Please select the location and size of the perforation and upload an image of the perforation.

Note: If perforation is found in both areas please identify both perforation locations below.

A1

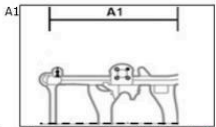

A1 Check the appropriate perforation size\*

Perforation Found during Frame Clearing for CRC-10mm and above

16mm or above

10 to 15mm

None

Comments: (500 Chars)

IMG\_1302.JPG 

A2

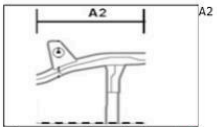

A2 Check the appropriate perforation size\*

Perforation Found during Frame Clearing for CRC-10mm and above

16mm or above

10 to 15mm

None

Comments: (500 Chars)

i. Once all sections have been completed, select the Submit button.

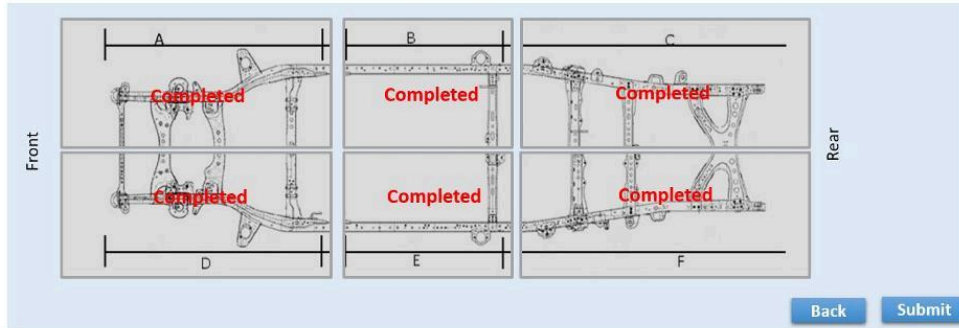

**NO Perforation Found**

j. If no perforation was not found, follow the directions as provided.

[Frame Inspection Case: FI000000001](#)  
[Inspection Summary: No Perforation Found](#)

The frame inspection has been completed successfully. Please print a copy of the inspection case and file it with the R.O. for warranty claim filing.

**Perforation Found**

k. If perforation was found, this application will be submitted to your Regional Office for review. The region office will review the inspection and provide feedback if the frame replacement is approved for future repair.

**STOP** DO NOT proceed with frame replacement or parts ordering until you are provided with approval from the Regional Office. Approval will be sent to the TIS inbox for the inspection, Service Manager and Parts Manager.

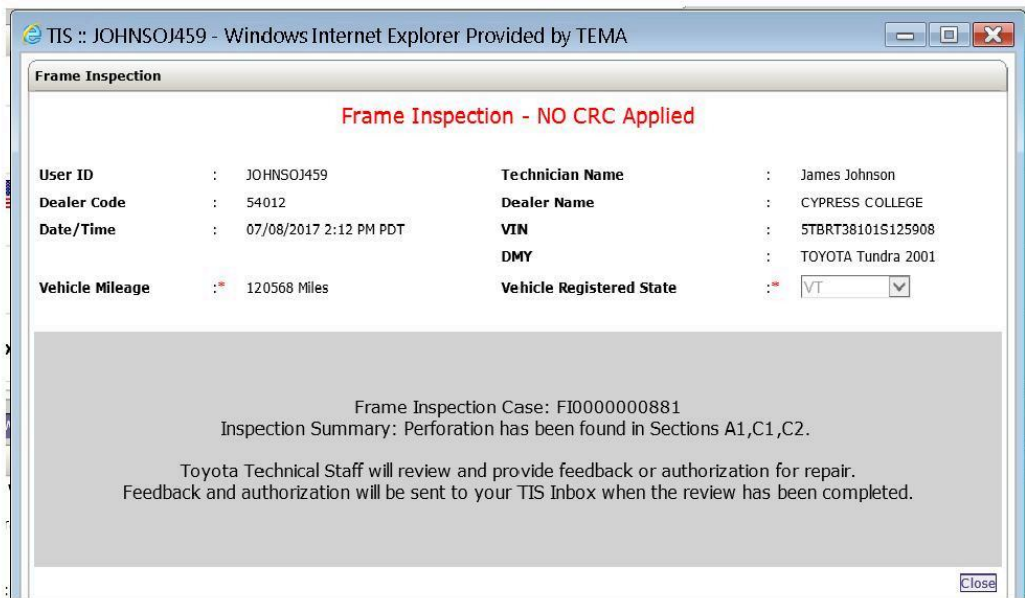

## IV. FRAME REPLACEMENT WORK PROCEDURE

### A. PERFORM PRELIMINARY VEHICLE INSPECTION

1. Perform health check and record any preexisting DTCs
2. Test drive the vehicle and inspect the following vehicle functions/current operating conditions prior to vehicle repair.
  - 4WD System (*4WD Only*)
  - Interior Lights
  - Exterior Lights
  - HVAC System
  - Audio System
  - Power Windows
  - Power Door Locks
  - All Gauges, Indicators and Warning Lights
  - Cooling Fans
  - Etc.
3. Documents the current vehicle operating condition on the [Frame Replacement Inspection Sheet](#).

### B. SAFETY CHECKLIST & PRECAUTIONS WHEN DRAINING THE FUEL SYSTEM



- Always remember **"SAFETY FIRST"**.
- Be extremely careful when handling fuel to prevent fires from occurring.
- Before beginning work on the fuel system, perform the following safety check list.
- Before removing any fuel system part, drain all fuel to prevent spilling.

#### 1. AIR VENTILATION

- Perform work in a well-ventilated area.
- DO NOT** work underground or in an area where fuel vapors may fill the room due to poor ventilation.
- Quickly clean up any spilled fuel with a dry cloth and dissipate the fuel vapors.
- Dry all cloths that have come in contact with fuel in a well-ventilated area and dispose of them properly (according to applicable local regulations).

#### 2. FIRES AND IGNITION SOURCES ARE STRICTLY PROHIBITED

- Fires and ignition sources are prohibited while working on the fuel system.
- Clearly display the sign found on the next page stating **"WORKING WITH GASOLINE, NO FIRES OR IGNITION SOURCES"**.
- Smoking is prohibited near the work area.
- DO NOT** work in areas where there are welders, grinders, drills, electric motors, heaters, etc.
- DO NOT** use work lamps or any other electrical appliance due to the risk of sparks flying from the power switch or a rise in temperature.
- DO NOT** use metal hammers while working, due to the risk of flying sparks.
- DO NOT** start any engines or perform any of the above in neighboring work bays.

#### 3. FIRE EXTINGUISHER

- Have a fire extinguisher ready and available before beginning work.

#### 4. PREVENT STATIC ELECTRICITY

- To help prevent static electricity, lightly wet the floor with water, but not to the point where it creates a hazardous working condition.
- Place appropriate warning cones or stand signs around the area as a caution.

#### 5. PRECAUTIONS WHEN USING A LIFT

- For bays equipped with auto lifts, cover all access cover joints with duct tape.
- In the event that fuel has leaked inside the auto lift, remove the access cover and clean up any spilled fuel. Dissipate fuel vapors until the smell is gone.

#### 6. PREVENT THE FUEL FROM SPRAYING

- When disconnecting any fuel tubes, pipes, hoses or connectors there may still be some pressure remaining, even after discharging the system. To prevent the fuel from spraying, cover the tubes, pipes or connectors with a shop rag before disconnecting.
- Remember to always wear protective goggles especially when disconnecting fuel tubes, pipes, hoses or connectors.

#### 7. PREVENT THE FUEL FROM CONTACTING OTHER PARTS

- Do not allow the fuel to come in contact with any parts made of rubber or leather.

#### 8. ASSIGN A SAFETY SUPERVISOR

- Assign a safety supervisor to be in charge of all safety precautions and fire hazards around the work area.



■ Copiar y exhibir al trabajar

**TRABAJANDO CON  
GASOLINA**

**NINGÚN INCENDIOS**

**NINGUNA FUENTE  
DE IGNICIÓN**

Supervisor

### C. REMOVE THE BED ASSY



- If the frame is perforated, **ONLY** raise the vehicle high enough to remove the tires.
- For added safety and support place jack stands under the front and rear portions of the frame.
- **DO NOT** work directly underneath the vehicle when performing bed assy removal.
- The actual vehicle specs, equipment and parts required may differ than what is shown. Please use the correct specifications and parts for the model you are working on.
- For additional repair information, please reference the appropriate repair manual found on TIS for the vehicle you are working on.

#### 1. CENTER THE VEHICLE BETWEEN THE LIFT ARMS

- Verify the vehicle is aligned with the center point of the lift to prevent interference and damage to the frame and/or lift.

#### 2. REMOVE THE FOLLOWING PARTS

- Rear Bumper Assy
- Rear Tail/Combination Light LH/RH
- Rear Mudguard LH/RH (If Equipped)
- Side Step Assy LH/RH (If Equipped)
- Rocker Panel Molding LH/RH (If Equipped)
- Body Rocker Panel Molding Assy LH (If Equipped)
- Outside LH Back Door Molding Sub-Assy (If Equipped)
- Quarter Panel Wheel Opening Molding LH
- Left Rear Wheel Well Liner

**NOTE:** Be careful not to damage the rear tail/combination lights when removing them.

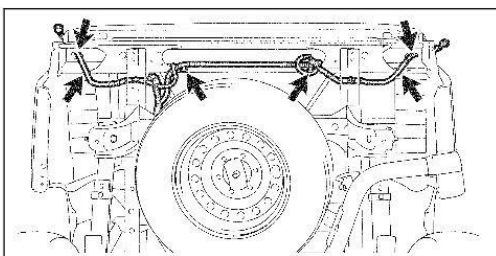

#### 3. REMOVE THE WIRE HARNESS

- Disconnect the clamps, connectors and the frame wire harness from the bed assy.

**NOTE:**

- The number of connectors may differ depending on the vehicle specification.
- Be careful not to damage the wire harness clamps when removing them.

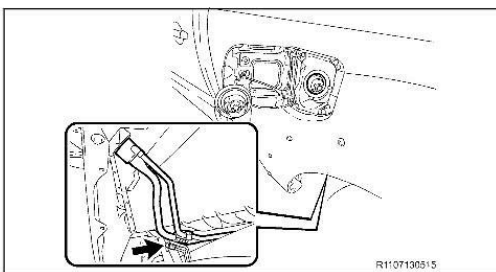

#### 4. DISCONNECT THE FUEL INLET PIPE SUB-ASSY

- Remove the bolt and disconnect the fuel inlet pipe sub-assy.

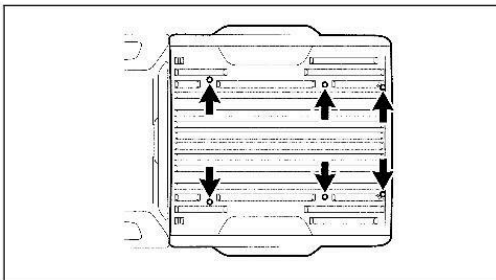

#### 5. REMOVE THE BED ASSY

- Using a Torx® T55H Socket, remove the 6 Torx® bolts from the bed assy.

**NOTE:**

- Use 4 or more people to remove the bed assy from the frame.
- Evenly support the bed assy when removing it.
- Be careful not to damage the filler tubes when removing the bed.

## D. DISCHARGE THE FUEL SYSTEM PRESSURE



- **DO NOT** disconnect any part of the fuel system until you have discharged the fuel system pressure.
- Even after discharging the fuel system pressure, place a piece of cloth around the tubes, pipe, hoses and connectors as you separate them to reduce the risk of fuel spraying on yourself, in the engine compartment and onto other parts.
- For additional repair information, please reference the appropriate repair manual in TIS for the vehicle you are working on.

### 1. CHECK FOR DTCs

### 2. RECORD THE RADIO STATION PRESETS

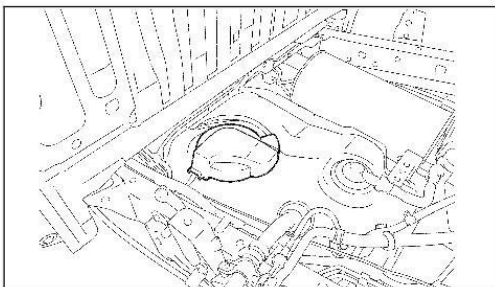

### 3. DISCHARGE THE FUEL SYSTEM PRESSURE

- a) Remove the No. 2 fuel tank protector. *(If Equipped)*

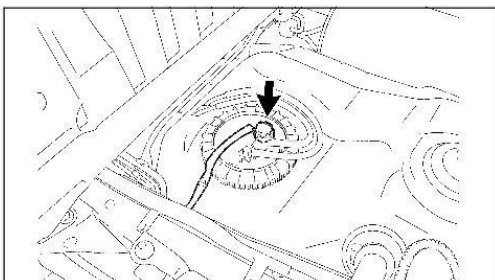

- b) Disconnect the fuel pump connector.  
 c) Start the engine.  
 d) After the engine, has stopped, turn the ignition switch OFF.  
 e) Crank the engine again to check that it does not start.

**NOTE:** Please make sure to follow the procedure listed above. This will prevent a large amount of gasoline from spilling out when high pressure fuel tube is disconnected.

### 4. DISCONNECT THE NEGATIVE (-) BATTERY TERMINAL

**NOTE:** Wait 90 seconds after the negative (-) terminal cable is disconnected from the battery before proceeding. Doing so will prevent the SRS from being deployed (i.e. airbag, seat belt pretensioner, etc.).

## E. REMOVE THE CAB BODY ASSY



- If the frame is perforated, **ONLY** raise the vehicle high enough to remove the tires.
- For added safety and support place jack stands under the front and rear portions of the frame.
- **DO NOT** work directly underneath vehicle when performing cab assy removal, unless noted.
- The actual vehicle specs, equipment and parts required may differ than what is shown. Please use the correct specs and parts for the model you are working on.
- For additional repair information, please reference the appropriate repair manual in TIS for the vehicle you are working on.

### 1. REMOVE THE ENGINE UNDER COVERS

**NOTE:** Use precaution when performing this step, as you will need to work underneath the vehicle.

### 2. EVACUATE THE REFRIGERANT FROM THE AIR CONDITIONING SYSTEM

### 3. DRAIN THE FOLLOWING FLUIDS

- Coolant (including engine block)
- Brake Fluid
- Clutch Fluid (*Manual Transmission Vehicles Of 1GR-FE Only*)
- Front Differential Fluid (*4WD Only*)

**NOTE:** **DO NOT** remove the radiator cap while the radiator and engine are hot, doing so may cause the coolant to spray out causing potential injuries.

### 4. REMOVE THE FOLLOWING BODY COMPONENTS

- Radiator Grille
- Front Bumper Filler LH/RH
- Front Fender Mudguard LH/RH
- Front Bumper Assy
- Front Bumper Reinforcement
- Front No.2 Bumper Extension Sub-assy LH/RH

### 5. REMOVE THE FOLLOWING INTERIOR COMPONENTS

- Front Door Scuff Plate LH/RH
- Front Floor Footrest
- Cowl Side Trim Board LH/RH

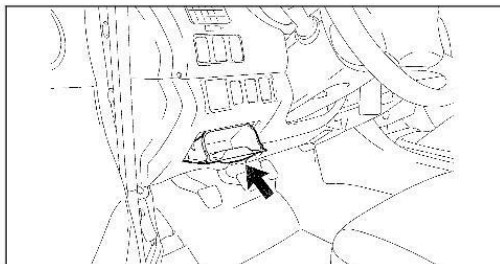

### 6. REMOVE THE INSTRUMENT PANEL BOX

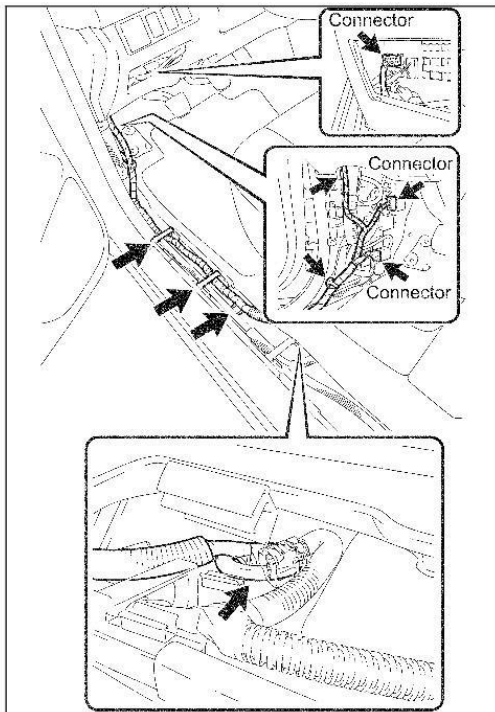

## 7. DISCONNECT THE FRAME WIRE HARNESS

- Disconnect the 5 clamps.
- Disconnect the connector(s).
- Remove the frame wire harness grommet from the cab assy.
- Pull out the frame wire harness from the vehicle cab assy.

**NOTE: The number of connectors may differ depending on the model.**

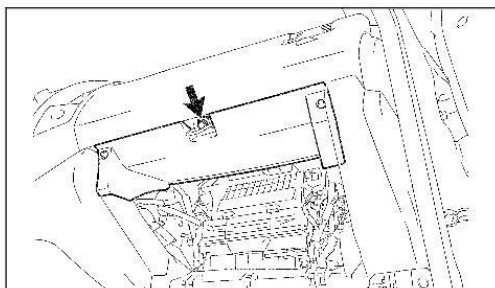

## 8. REMOVE THE GLOVE BOX AND LOWER INSTRUMENT PANEL FINISH PANEL

- Remove the glove box.
- Remove the bolt and the lower instrument panel finish panel.

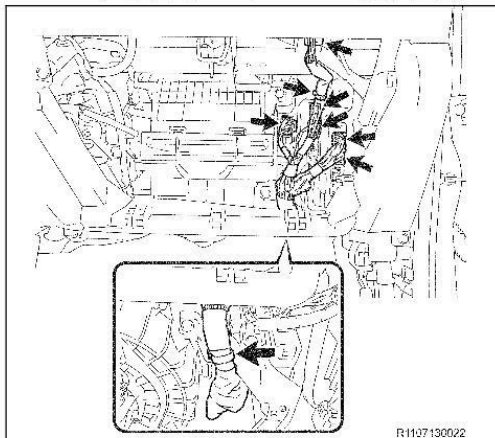

## 9. DISCONNECT THE ENGINE WIRE HARNESS

- Disconnect each connector and clamp from the ECM and remove the engine wire harness.

**NOTE: The number of connectors may differ depending on the model.**

## 10. REMOVE THE FOLLOWING PARTS

- Rear Console Box (*for Separate Seat Type*)
- Front Console Box
- Voltage Inverter Assy (*If Equipped*)
- Manual Transmission Shift Lever (*Manual Trans Vehicles Only*)

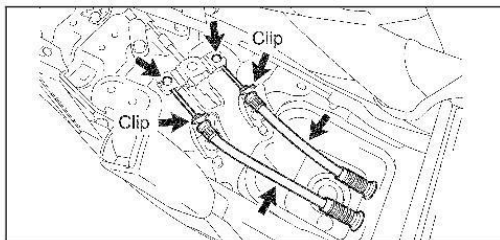

## 11. DISCONNECT THE PARKING BRAKE CABLES

### For Separate Seat Type:

- a) Remove the 2 clips.
- b) Disconnect the 2 parking brake cables.

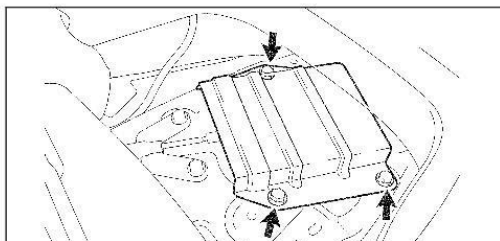

### For Bench Seat Type:

- c) Turn back the floor carpet.
- d) Remove the 3 bolts and the parking brake cable joint protector.

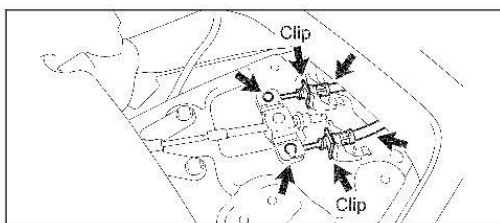

- e) Remove the 2 clips.
- f) Disconnect the 2 parking brake cables.

## 12. REMOVE THE FOLLOWING PARTS

- V-Bank Cover (*1GR-FE Only*)
- Air Cleaner Hose and Air Cleaner Assy

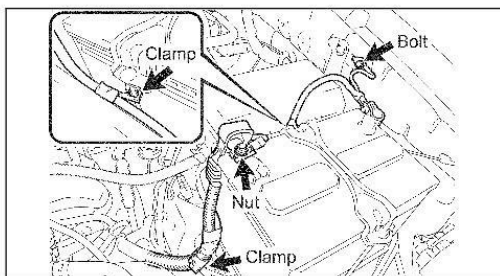

## 13. DISCONNECT THE NO.2 ENGINE WIRE HARNESS

- a) Remove the nut and disconnect the (+) positive battery cable.
- b) Remove the bolt and disconnect the ground wire.
- c) Disconnect the 2 clamps.

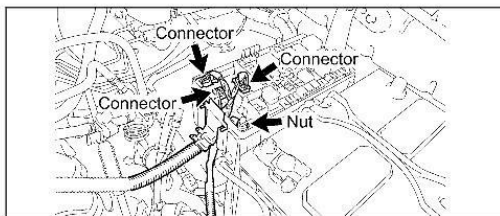

- d) Remove the No.1 upper relay block cover.
- e) Disconnect the 3 connectors.
- f) Remove the nut and disconnect the fuse box wire harness.

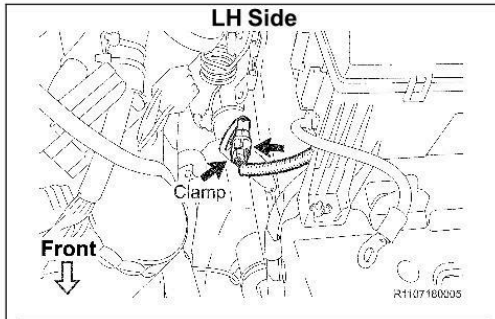

#### 14. DISCONNECT THE SKID CONTROL SENSOR WIRE HARNESS

- a) Disconnect the harness clamp and front skid control sensor connector.
- b) Repeat the procedure on the opposite side.

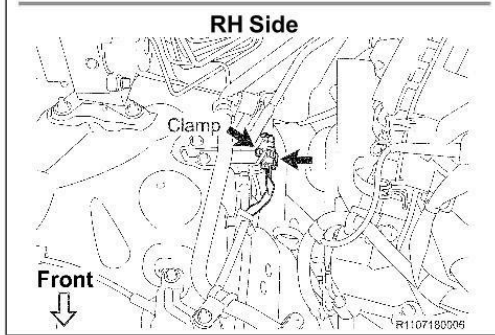

#### 15. DISCONNECT THE FRONT DIFFERENTIAL BREATHER TUBES (4WD ONLY)

- a) Disconnect the front differential breather tubes.

**NOTE:** There may be 2 front differential breather tubes depending on the vehicle model.

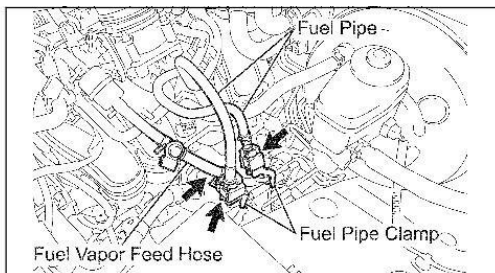
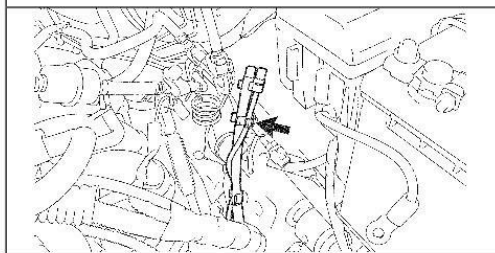

#### 16. DISCONNECT THE FUEL PIPES AND VAPOR FEED HOSE

- a) Remove the 2 fuel pipe clamps.
- b) Disconnect the No. 1 and No. 2 fuel pipe.

**NOTE:** Put a shop towel under the fuel pipe to catch any spilled fuel.

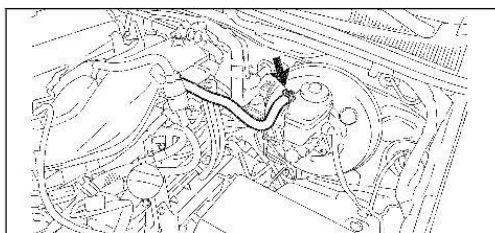

#### 17. DISCONNECT THE VACUUM HOSE

- a) Disconnect the vacuum hose.

**18. REMOVE THE FOLLOWING PARTS**

- Radiator Support to Frame Seal
- Radiator Inlet Hose
- Radiator Outlet Hose
- Fan Shroud
- Radiator Assy

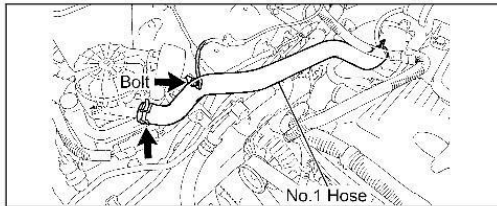
**19. DISCONNECT THE NO.1 HOSE (2TR-FE ONLY)**

- Disconnect the No.1 hose.

**20. DISCONNECT THE GROUND WIRE (2TR-FE ONLY)**

- Remove the bolt and disconnect the ground wire.

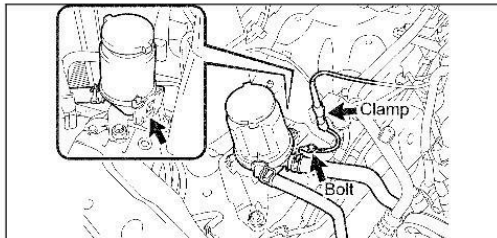
**21. DISCONNECT POWER STEERING PUMP OIL RESERVOIR ASSY (1GR-FE ONLY)**

- Disconnect power steering pump oil reservoir assy.

**22. DISCONNECT THE GROUND WIRE (1GR-FE ONLY)**

- Remove the bolt and disconnect the clamp and the ground wire.

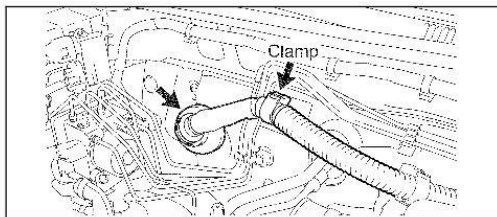
**23. DISCONNECT THE ENGINE WIRE HARNESS**

- Disconnect the clamp.
- Remove the engine wire harness container from the cowl panel.

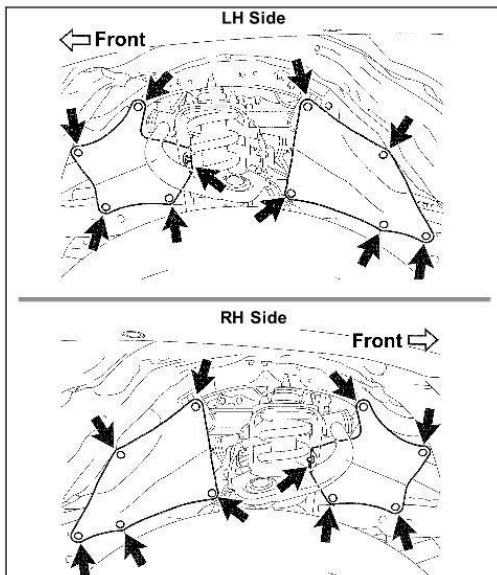
**24. DISCONNECT THE WATER / HEATER HOSES, ENGINE SIDE****25. REMOVE THE FRONT FENDER APRON SEALS****4WD, Pre-Runner Only (Shown):**

- Remove the 20 clips and 4 front fender apron seals.

**2WD Only:**

- Remove the 22 clips and 4 front fender apron seals.

## 26. DISCONNECT THE AIR CONDITIONING DISCHARGE AND SUCTION HOSES FROM THE COMPRESSOR

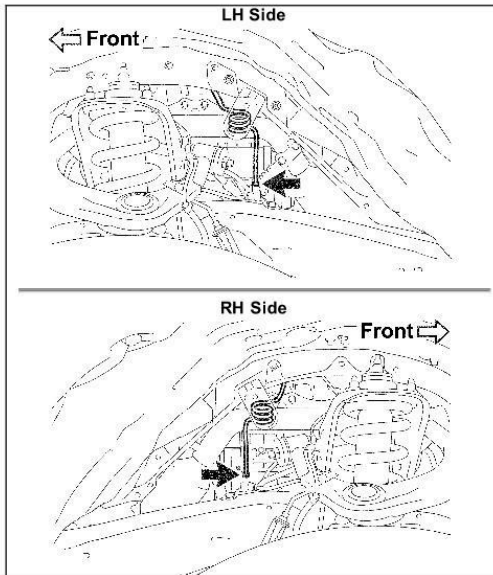

## 27. DISCONNECT THE FRONT BRAKE TUBES

- Disconnect the front brake tube.
- Repeat the procedure on the opposite side.

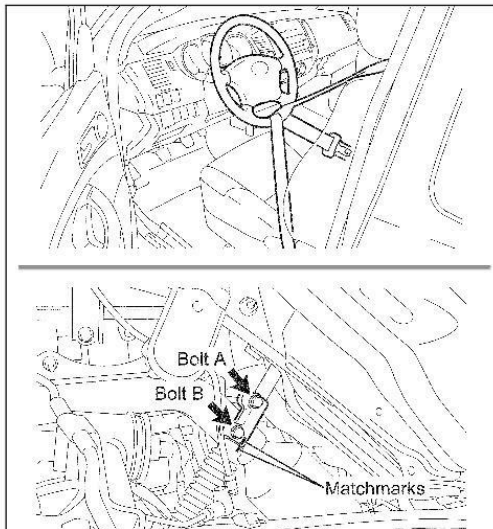

## 28. DISCONNECT THE STEERING SLIDING YOKE

**NOTE: Use precaution when performing this step, as you will need to work underneath the vehicle.**

- Make sure the front wheels are in a straight-ahead position and the steering wheel is centered.
- Using the seat belt, hold the steering wheel in position as shown in the illustration, to prevent damage to the spiral cable.
- Place match marks on the steering sliding yoke and No.2 intermediate shaft.
- Loosen bolt (A) and remove bolt (B).
- Disconnect the steering sliding yoke from the No.2 intermediate shaft.

**NOTE: If the steering sliding yoke is stuck, tap it from below with a brass hammer to disconnect it.**

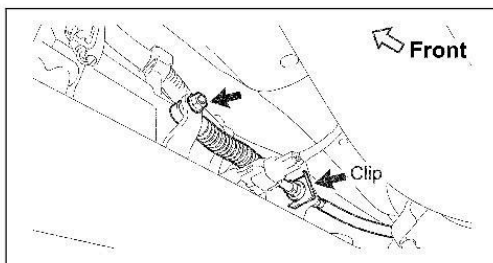

## 29. DISCONNECT THE SHIFT CABLE (AUTO TRANS ONLY)

### Cable Type:

- Remove the clip.
- Remove the nut and disconnect the shift cable.

### Rod Type:

- Remove the pin and clip, disconnect the shift cable.

**NOTE: Use precaution when performing this step, as you will need to work underneath the vehicle.**

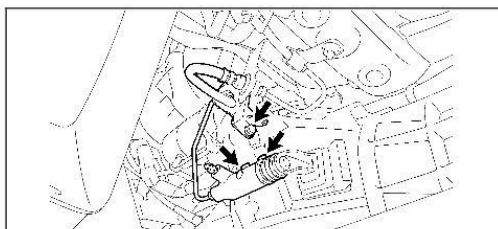

**30. DISCONNECT THE CLUTCH RELEASE CYLINDER ASSY  
(2TR -FE MANUAL TRANS ONLY)**

- a) Remove the bolt and disconnect the clutch hose.
- b) Remove the 2 bolts and disconnect the clutch release cylinder.

**NOTE: Use precaution when performing this step, as you will need to work underneath the vehicle.**

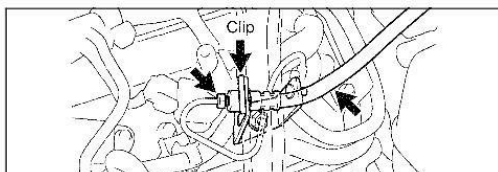

**31. DISCONNECT THE NO.1 CLUTCH HOSE  
(1GR-FE MANUAL TRANS ONLY)**

- a) Disconnect the clutch release cylinder tube from the clutch hose.
- b) Remove the clip and disconnect the clutch hose.

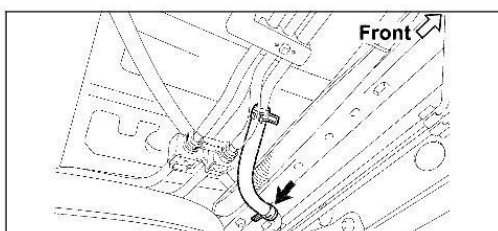

**32. DISCONNECT THE NO.2 FUEL HOSE**

- a) Remove the clip and disconnect the No.2 fuel hose.

**NOTE: Use precaution when performing this step, as you will need to work underneath the vehicle.**

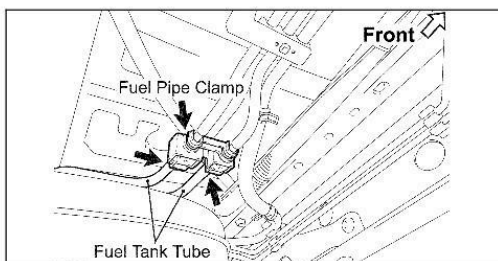

**33. DISCONNECT THE FUEL TANK TUBES**

- a) Remove the fuel pipe clamp.
- b) Disconnect the 2 fuel tank tubes.

**NOTE: Use precaution when performing this step, as you will need to work underneath the vehicle.**

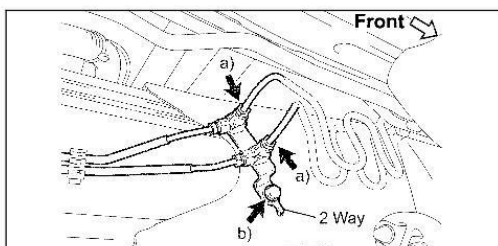

**34. DISCONNECT THE REAR BRAKE TUBES**

- a) Disconnect the 2 rear brake tubes.
- b) Remove the bolt and disconnect the 2 way.

**NOTE: Use precaution when performing this step, as you will need to work underneath the vehicle.**

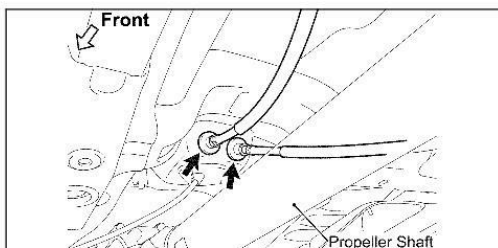

**35. DISCONNECT THE PARKING BRAKE CABLES**

**NOTE: Use precaution when performing this step, as you will need to work underneath the vehicle.**

**36. REMOVE THE FOLLOWING PARTS**

- Floor Board No.1/No.2 (*Access Cab Only*)
- Seat Floor Box (*Access Cab Only*)
- Rear Floor Side Service Hole Cover LH/RH (*Access Cab Only*)
- Luggage Compartment Side Tray (*Double Cab Only*)
- No.1 w/ Box Speaker Assy (*If Equipped*)

**37. REMOVE THE CAB BODY ASSY USING AN ABOVE GROUND LIFT**

- a) Remove the 6 nuts and 6 washers.
- b) Set the lift arms under the cab body assy so they **DO NOT** interfere with the frame or cab mounts.
- c) Check that all wire harnesses, hoses, cables and the steering shaft are disconnected.
- d) Mark the location of the tires so it will be easier to install the cab onto the new frame.
- e) Lift the cab assy up slowly, making sure it does not interfere with anything while being raised.
- f) Raise the cab assy high enough so that the top of the engine clears the lowest point of the cab assy.
- g) Pull the frame assy out from under the vehicle.
- h) Lower the cab assy all the way down and leave it on the lift.

**NOTE:**

- **Center the cab assy weight on the lift arms so that it does not slant/tilt to one side.**
- **Raise the cab assy slightly off the frame and verify that it is held securely by the lift arms.**
- **The center of gravity of the cab body may become nose heavy depending on placement of the lift arm which could cause the cab to fall when lifted. To prevent this, use weights to establish a balance and secure the cab body to the lift arm using ratchet tie down belts.**
- **DO NOT work directly underneath the vehicle when pulling the frame assy out from under.**
- **DO NOT remove the cab mount bolts, they will be used as guides during cab assy reinstallation.**

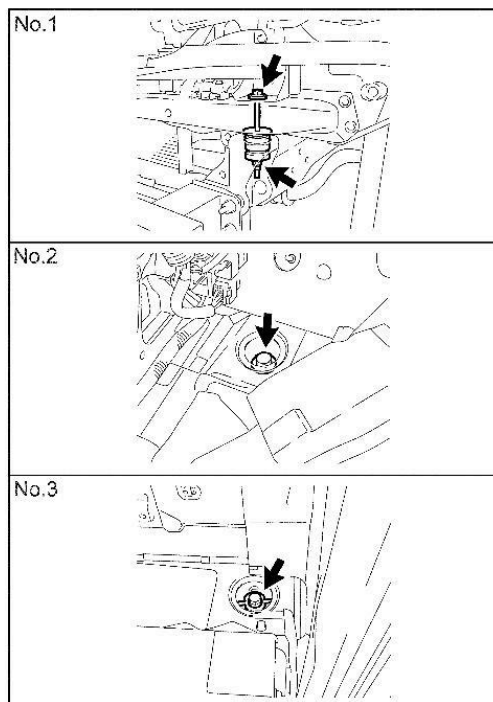
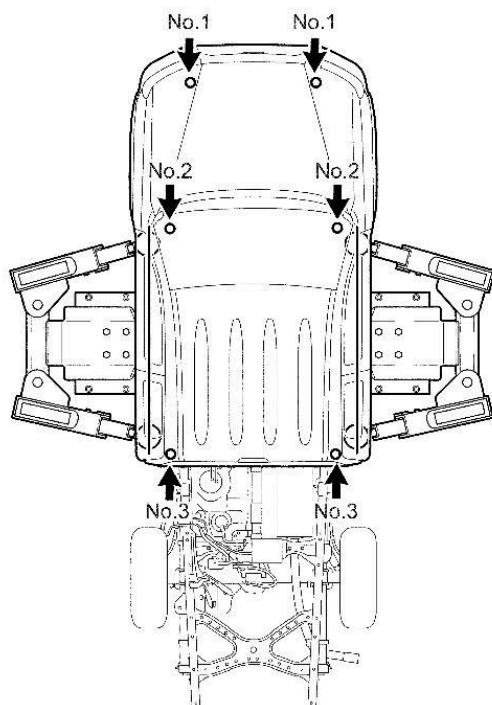

## F. DISASSEMBLE THE FRAME

### 1. PLACE THE FRAME ON A LIFT

- Place the frame on the lift, and secure it with a ratcheting tie down strap. This will prevent the frame from tilting or falling off as parts are removed.
  - Ratcheting Tie Downs: Qty 1 (Length: 2 in X 27 ft and Min. Work Load Capacity: 3,000 lbs)**

### 2. REMOVE THE FOLLOWING PARTS

- Wheels
- Front Propeller Shaft Assy (*4WD Only*)
- Rear Propeller Shaft Assy
  - Insert **SST 09325-40010** into trans after the Rear Prop Shaft is removed to prevent oil leakage (*2WD Only*)
- Propeller Shaft Heat Insulator (*If Equipped*)
- Exhaust Pipe Stopper Bracket (*If Equipped*)

**NOTE: Place match marks on the front (if equipped) and rear propeller shafts prior to removal.**

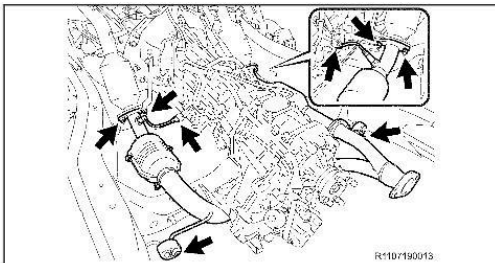
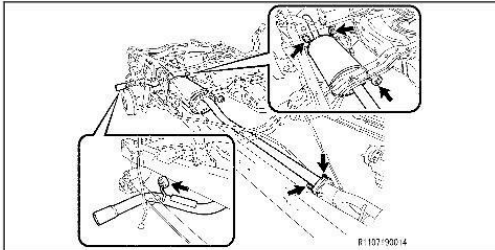

### 3. REMOVE THE EXHAUST SYSTEM (1GR-FE ONLY)

- Remove the 2 bolts and 4 exhaust pipe supports.
- Remove the center exhaust pipe assy and exhaust pipe supports.
- Remove the exhaust pipe gasket.
- Disconnect the 2 oxygen sensor connectors.
- Remove the 6 nuts and 2 exhaust pipe supports.
- Remove the front exhaust pipe assy and exhaust pipe supports.
- Remove the 2 exhaust pipe gaskets.

### 4. REMOVE THE EXHAUST SYSTEM (2TR-FE ONLY)

- Remove the 2 bolts and 4 exhaust pipe supports.
- Remove the center exhaust pipe assy and exhaust pipe supports.
- Remove the exhaust pipe gasket.
- Disconnect the 2 oxygen sensor connectors.
- Disconnect the 2 oxygen sensor wire harness clamps.
- Remove the 2 bolts and exhaust pipe support.
- Remove the front exhaust pipe assy and exhaust pipe supports.
- Remove the 2 exhaust pipe gaskets.

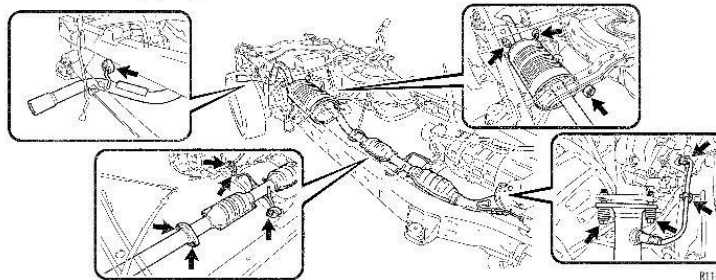

**5. REMOVE THE FOLLOWING PARTS**

- No.1 Fuel Tank Protector Assy (If Equipped)
- Fuel Tank Strap
- Fan V-belt
- Fuel Tank
- Charcoal Canister Assy

**6. REMOVE AND SET ASIDE THE POWER STEERING PUMP ASSY**

- a) Disconnect the connector.
- b) Disconnect the clamp. (1GR-FE Only)
- c) Remove the bolt and disconnect the ground wire. (1GR-FE Only)
- d) Remove the 2 bolts and the power steering vane pump.

**NOTE:**

- **DO NOT disconnect the power steering pump hoses or tubes.**
- **Keep the power steering pump reservoir upright to prevent the fluid from leaking out.**

**7. REMOVE THE FOLLOWING PARTS**

- Intake Air Surge Tank (1GR-FE Only)
- Intake Air Connector (2TR-FE Only)

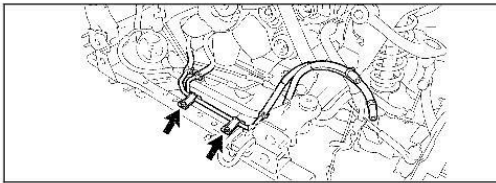

**8. DISCONNECT THE OIL COOLER TUBE (AUTO TRANS ONLY)**

- a) Remove the bolts and disconnect the oil cooler tube.

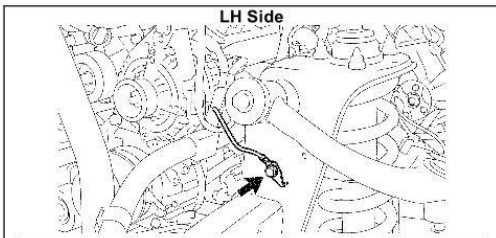

**9. REMOVE THE ENGINE AND TRANSMISSION ASSY**

- a) Remove the bolt and disconnect the ground wire. (LH Side)
- b) Disconnect the connector and clamp. (4WD Only)
- c) Disconnect and remove the necessary items/parts to prepare the engine and transmission assy for removal.
- d) Install the engine hanger.

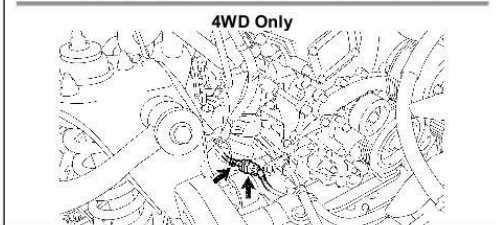

**For 1GR-FE:**  
 12281-31060 = No.1 Engine Hanger  
 12282-31040 = No.2 Engine Hanger  
 90119-08A87 = 4 Bolts

**For 2TR-FE:**  
 12281-75040 = No.1 Engine Hanger  
 12281-75040 = No.2 Engine Hanger  
 91552-A1020 = 2 Bolts

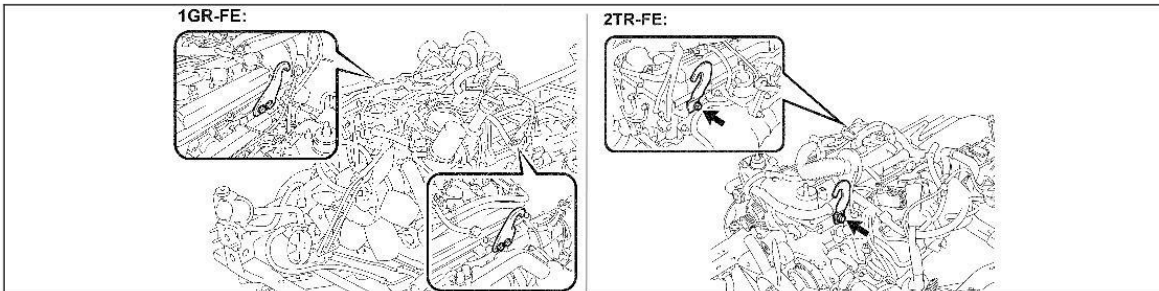

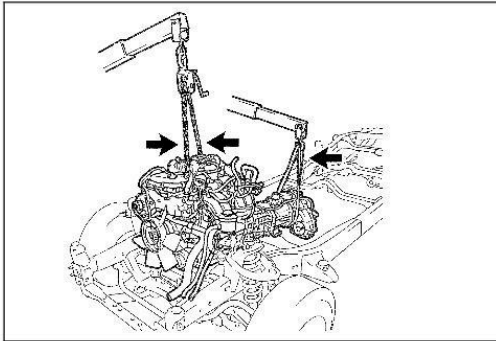

e) Remove the engine and transmission assy.

**NOTE:**

- **ALWAYS** use 2 engine hoists/cranes to lift it.
- **DO NOT** use 1 engine hoist/crane to lift the engine & transmission assy, as the unbalanced weight may lead to an accident or injury.
- **ONLY** use engine hoists/cranes that can properly support the weight of the engine and transmission assy.
- **Carefully** adjust the 2 engine hoists/cranes used so that the engine and transmission assy is properly balanced.

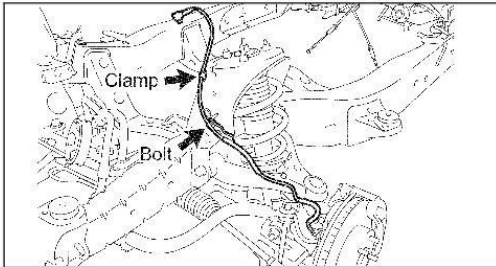

**10. DISCONNECT THE FRONT SKID CONTROL SENSOR WIRE HARNESS (2WD ONLY)**

- a) Remove the bolt, disconnect the clamp and skid control sensor wire harness.
- b) Repeat the procedure on the opposite side.

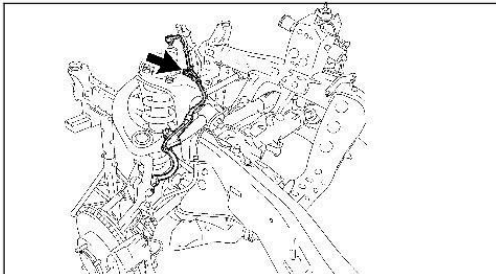

**11. DISCONNECT THE FRONT SKID CONTROL SENSOR WIRE HARNESS (4WD, PRE-RUNNER ONLY)**

- a) Remove the bolt and disconnect the skid control sensor wire harness.
- b) Repeat the procedure on the opposite side.

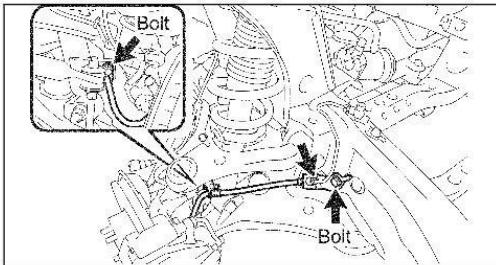

**12. DISCONNECT THE FRONT BRAKE HOSE (2WD ONLY)**

- a) Disconnect the front brake tube from the brake hose.
- b) Remove the 2 bolts and disconnect the front brake hose and flexible hose bracket.
- c) Repeat the procedure on the opposite side.

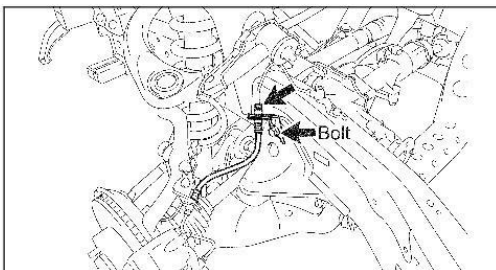

**13. DISCONNECT THE FRONT BRAKE HOSE (4WD, PRE-RUNNER ONLY)**

- a) Disconnect the front brake tube from the brake hose.
- b) Remove the bolt and disconnect the front brake hose and flexible hose bracket.
- c) Repeat the procedure on the opposite side.

**14. REMOVE THE FOLLOWING PARTS**

- Front Axle Hub Grease Cap (4WD Only)
- Front Axle Shaft Nut (4WD Only)
- Tie Rod End\*
- Front Stabilizer Link Assy

\* SST 09610-20012 (2WD), SST 09628-62011 (4WD, Pre-Runner) disconnect the tie rod end.

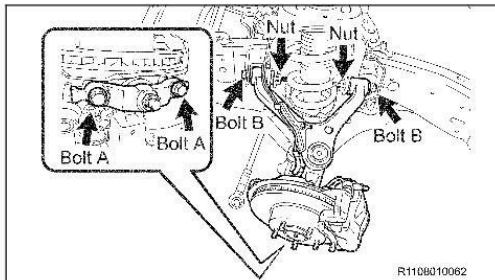
**15. REMOVE THE FRONT SUSPENSION UPPER ARM AND STEERING KNUCKLE ASSY (2WD ONLY)**

- Remove the 2 bolts (A).
- Remove the 2 bolts (B), 2 nuts, 2 washers and front suspension upper arm w/ steering knuckle.
- Repeat the procedure on the opposite side.

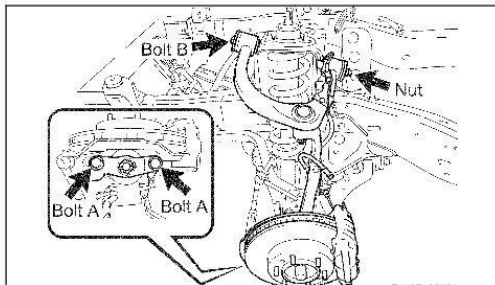
**16. REMOVE THE FRONT SUSPENSION UPPER ARM AND STEERING KNUCKLE ASSY (4WD, PRE-RUNNER ONLY)**

- Remove the 2 bolts (A).
- Remove the bolt (B), nut, 2 washers and front suspension upper arm w/ steering knuckle.
- Repeat the procedure on the opposite side.

**NOTE:** If the drive shaft is difficult to disconnect, tap the drive shaft loose with a plastic hammer.

**17. REMOVE THE FOLLOWING PARTS**

- Front Drive Shaft Assy (4WD Only) \*
  - Front Suspension Member Brace Sub-Assy
  - Front Stabilizer Bar
  - Front Shock Absorber Assy
  - Power Steering Link Assy w/ Pump
  - Front Differential Carrier (4WD Only)
  - Lower Ball Joint\*\*
  - Front Spring Bumper\*\*\*
- \*SST 09520-24010 (09520-32040), 09520-01010
  - \*\*SST 09628-00011
  - \*\*\*SST 09922-10010-01

**NOTE:**

- When removing the power steering link with the pump, have one person support the power steering link and the other support the pump and keep it upright to avoid fluid leakage.
- If the drive shaft is difficult to remove tap it with a plastic hammer.
- Be careful not to damage the dust cover and oil seal.

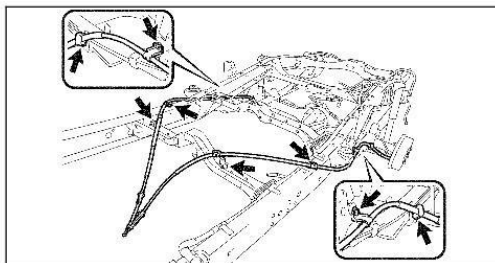
**18. REMOVE THE PARKING BRAKE CABLES**

- Remove the 8 bolts and parking brake cables.

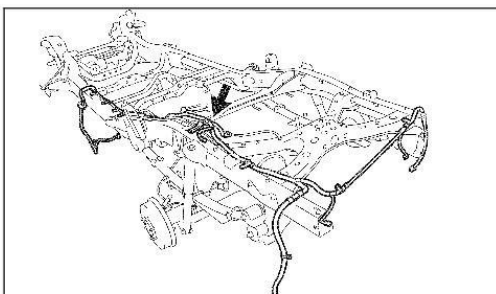

### 19. REMOVE THE FRAME WIRE HARNESS

- Remove the bolt and disconnect the ground wire *(If Equipped)*.
- Disconnect the clamps and remove the frame wire harness.

#### NOTE:

- The number of wire harness clamps will differ depending on the vehicle specification.
- Take care not to damage or break the wire harness clamps during removal.

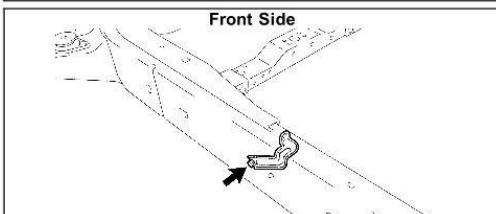

### 20. REMOVE THE HARNESS BRACKETS

- Remove the 2 bolts and 2 brackets.

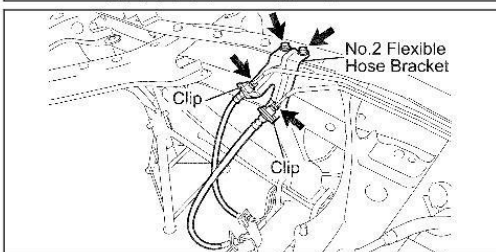

### 21. DISCONNECT THE BRAKE HOSE

- Disconnect the No.5 rear brake tube.
- Disconnect the No.6 rear brake tube.
- Remove the 2 clips and 2 bolts, disconnect the brake hose and the No.2 flexible hose bracket.

### 22. REMOVE THE FOLLOWING PARTS

- Rear Stabilizer Bar *(If Equipped)*
- Rear Shock Absorber Assy
- Rear Differential Assy
- No.1 Rear Spring Bumper *(2WD Only)*



**4WD and PreRunner vehicles will not have leaf springs replaced or will have them replaced under E02. If the vehicle already had E02 performed there is no need to separate the rear differential from the leaf springs, remove the leaf springs and rear diff as an assembly.**

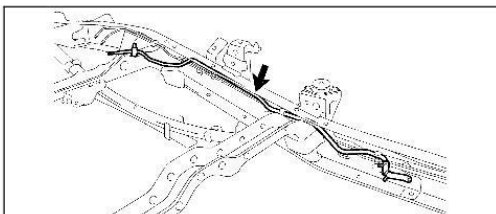

### 23. REMOVE THE NO.2 CHARCOAL CANISTER PIPE

- Disconnect the clamps and remove the No.2 charcoal canister pipe.

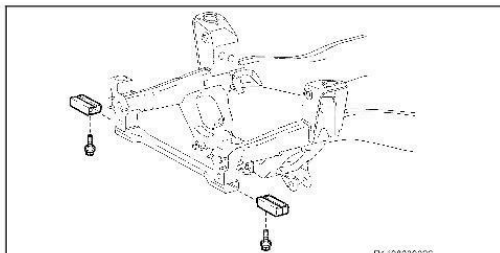

**24. REMOVE THE FRAME AUXILIARY CROSSMEMBER EXTENSIONS (IF EQUIPPED)**

- a) Remove the 2 bolts and frame auxiliary crossmember extensions.

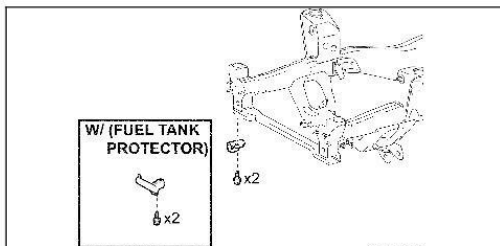

**25. REMOVE THE HOOK**

- a) Remove the 2 bolts and hook.

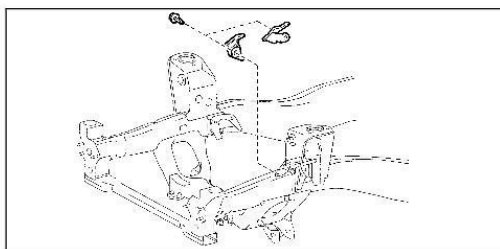

**26. REMOVE THE REAR ENGINE MOUNTING REINFORCES (1GR-FE ONLY)**

- a) Remove the 2 bolts and 2 rear engine mounting reinforces.

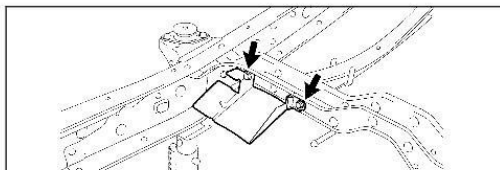

**27. REMOVE THE PARKING BRAKE CABLE HEAT INSULATOR (IF EQUIPPED)**

- a) Remove the 2 bolts and parking brake cable heat insulator.

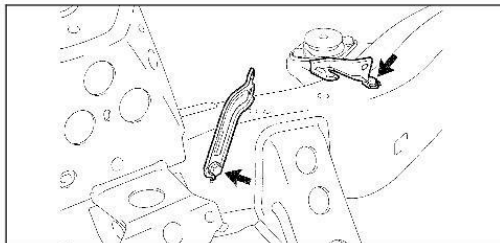

**28. REMOVE THE OXYGEN SENSOR BRACKETS (2TR-FE ONLY)**

- a) Remove the 2 bolts and 2 brackets.

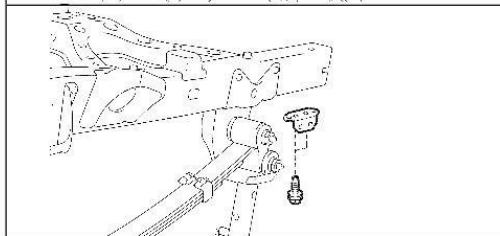

**29. REMOVE THE NO.1 RECEIVER HITCH ATTACHMENT REINFORCEMENT (IF EQUIPPED)**

- a) Remove the 2 bolts and No.1 receiver hitch attachment reinforcement.

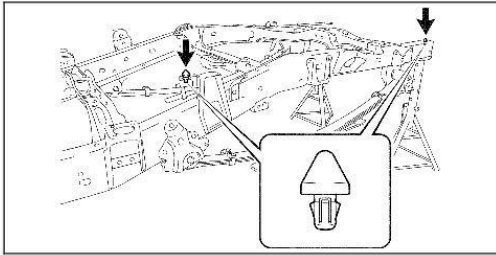
**30. REMOVE THE CLIPS****31. REMOVE THE FOLLOWING PARTS**

- Front Suspension Lower Arm
- Cab Mounts (QTY:6)
- Rear Leaf Spring Assy

**32. REMOVE THE FRAME FROM THE LIFT**

- a) Remove the ratcheting tie down strap and the frame from the lift.

**G. ASSEMBLE THE NEW FRAME**

**1. PLACE THE NEW FRAME ON THE LIFT**

- Place the **NEW** frame on the lift, and secure it with a ratcheting tie down strap.
  - Ratcheting Tie Downs: Qty 1 (Length: 2 in X 27 ft and Min. Work Load Capacity: 3,000 lbs)**

**2. INSTALL THE BODY PLUGS**

Note: The illustration shows only the right side if the body plug installation points are positioned similarly for both sides.

**STEP 3** Front →

**90950-01983**  
**90950-01987**  
**90950-01989**  
 R1110310001

**Step 3 (refer to the following illustration):**  
 a) Install the body plugs as follows into the side-rail.

**90950-01983×4**  
 TLL: 6 or 8 plugs

**90950-01989×2**

**90950-01987×2**  
**4WD ONLY**

**STEP 4** Front →

**90950-01987**  
 R1110310002

**Step 4 (refer to the following illustration):**  
 a) Install the body plugs as follows into the side-rail.

**90950-01987×4**  
 TLL: 4 plugs

**STEP 5** ← Front

**90950-01992** **90950-01990**  
**90950-01989**  
 R1110310003

**Step 5 (refer to the following illustration):**  
 a) Install the body plugs as follows into the side-rail.



**90950-01989×2** **90950-01990×2** **90950-01992×2**  
 TLL: 6 plugs



**STEP 6** ← Front

**90950-01991**  
 R1110310004

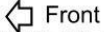
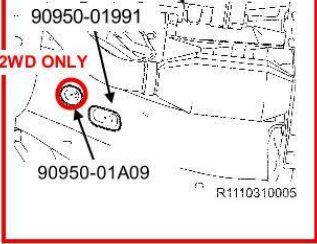
**Step 6 (refer to the following illustration):**  
 a) Install the body plugs as follows into the side-rail.

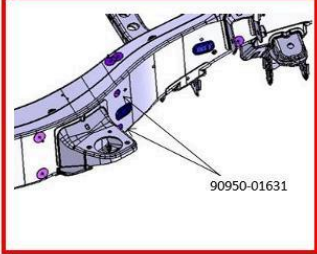
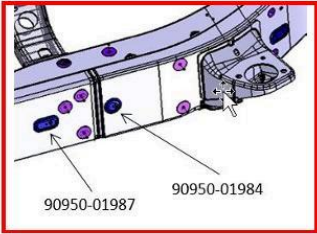
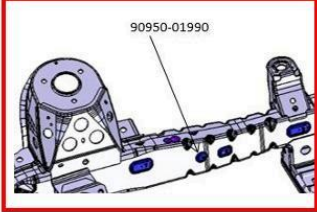
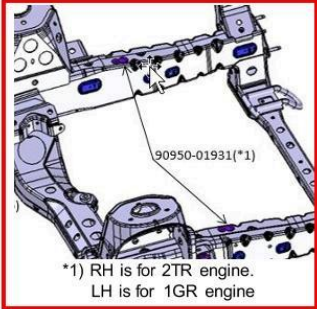
**90950-01991×2**  
 TLL: 2 plugs

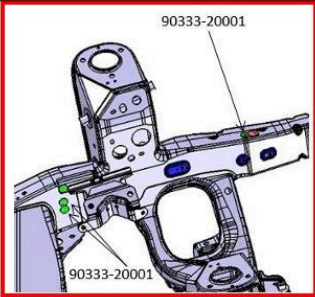
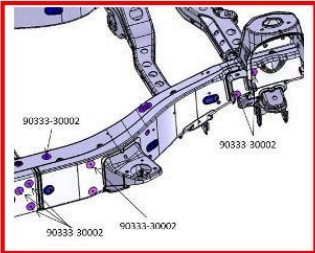
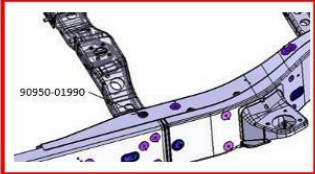
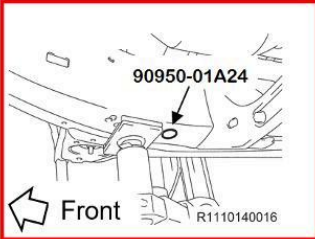
<p><b>STEP 7</b>  Front</p>  <p>90950-01991</p> <p><b>2WD ONLY</b></p> <p>90950-01A09</p> <p>R1110310005</p>	<p><b>Step 7 (refer to the following illustration):</b> a) Install the body plugs as follows into the side-rail.</p> <p><b>2WD ONLY</b></p>   <p><b>90950-01A09×2</b>      <b>90950-01991×2</b> TLL: 2 or 4 plugs</p>
 <p>90950-01631</p>	<p><b>Step 8 (refer to the following illustration):</b> a) Install the body plugs as follows into the side-rail.</p> <p><b>90950-01631×4</b> TLL: 4 plugs</p>
 <p>90950-01987      90950-01984</p>	<p><b>Step 8 (refer to the following illustration):</b> b) Install the body plugs as follows into the side-rail.</p> <p><b>90950-01984×2</b>      <b>90950-01987</b> TLL: 4 plugs      TTL: 2 plugs</p>
 <p>90950-01990</p>	<p><b>Step 9 (refer to the following illustration):</b> c) Install the body plugs as follows into the side-rail.</p> <p><b>90950-01990×2</b> TLL: 2 plugs</p>
 <p>90950-01931(*1)</p> <p>*1) RH is for 2TR engine. LH is for 1GR engine</p>	<p><b>Step 11 (refer to the following illustration):</b> d) Install the body plugs as follows into the side-rail.</p> <p><b>90950-01931×1</b> TLL: 1 plug</p>

	<p><b>Step 12 (refer to the following illustration):</b>  a) Install the body plugs as follows into the side-rail.</p> <p><b>90333-20001</b>  TLL: 10 plugs (4WD and PreRunner) or 2 plugs (2WD)</p>
	<p><b>Step 13 (refer to the following illustration):</b>  a) Install the body plugs as follows into the side-rail.</p> <p><b>90333-30002</b>  TLL: 28 plugs (4WD) or 36 plugs (2WD)</p>
	<p><b>Step 14 (refer to the following illustration):</b>  a) Install the body plugs as follows into the side-rail.</p> <p><b>90950-01990×2</b>  TLL: 2 plugs</p>
	<p><b>Step 15 (refer to the following illustration):</b>  a) Install the one way plug with the channel opening the sides of the vehicle so that water cannot enter the frame from tire spray.</p>  <p><b>90950-001A24×2</b>  TLL: 2 plugs</p>

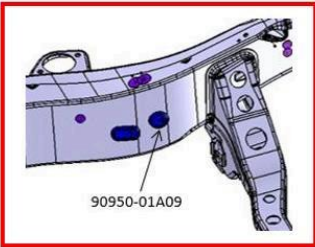

90950-01A09

**Step 16 (refer to the following illustration):**

a) Install the body plugs as follows into the side-rail.

**2WD ONLY**

**90950-01A09×2**  
TLL: 2 plugs

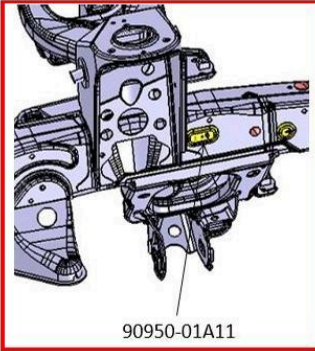

90950-01A11

**Step 17 (refer to the following illustration):**

a) Install the body plugs as follows into the side-rail.

**2WD ONLY**

**90950-01A11×2**  
TLL: 2 plugs

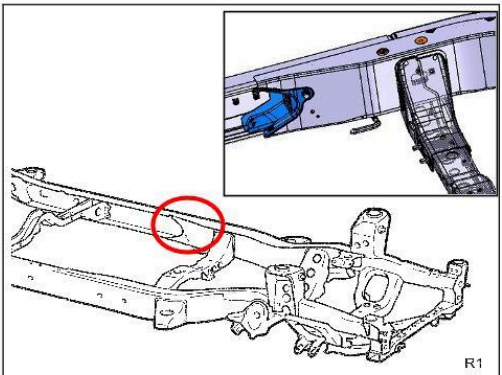

**3. INSTALL FRAME RAIL SEAL**

- a) Inspect the replacement frame on both sides with the frame seal temporarily installed as identified in the picture. Depending on when the service frame was produced will determine if the following are present:
- **Predrilled hole w/weld nut: Proceed to step b)**
  - **Predrilled hole w/o weld nut: Proceed to step c)**
  - **No hole is present: Proceed to step d)**

**Note: Both sides of the frame must be inspected because the hole status may differ from side to side.**

b) Install Frame Seal with Predrilled Hole with Weld Nut

1. Install the frame seal with the bolt.  
**Torque Spec: 29 N·m (21.5 ft·lbf)**

Part #	Part Name	Qty
90119-A0170	Bolt, Flange	2

2. Skip to step #4 on page 55

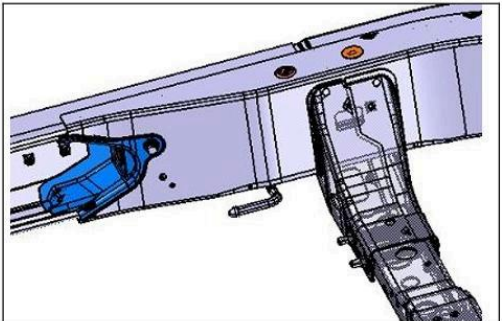

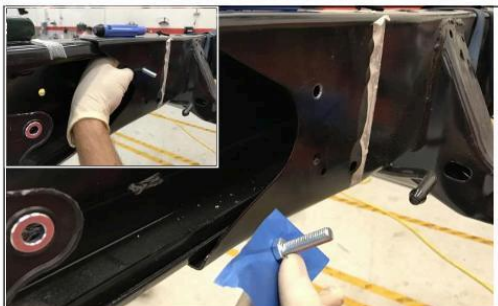
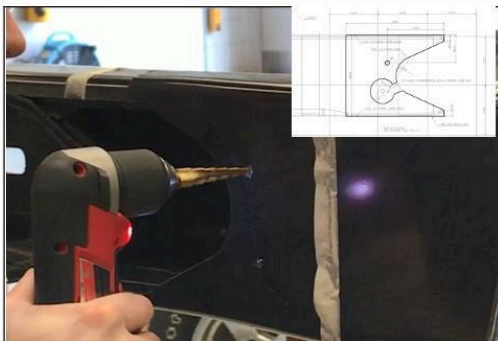
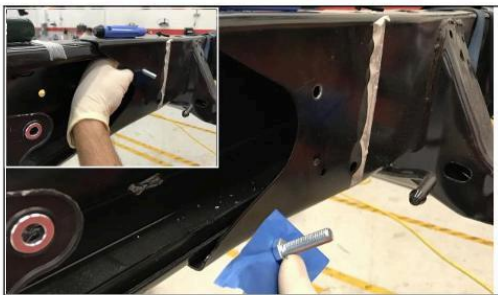

c) Install Frame Seal with Predrilled Hole w/o Weld Nut

1. Using tape secure bolt and washer to the back of the frame as shown.

**Note:** Using the tape will prevent the bolt from falling back into the frame rail when installing the seal and will prevent the bolt from spinning when torqueing the nut.

Part #	Part Name	Qty
90119-A0170	Bolt, Flange	2
90178-A0024	Nut	2

2. Install the frame seal and torque the nut to spec  
**Torque Spec: 18.5 N·m (14.0 ft-lbf)**
3. Skip to Step #4 on page 55

d) Install Frame Seal with No Hole in Frame

1. Using the template in the appendix of this T1 mark the hole on the inner frame rail for both the left and right side frame rail.
2. Use a center punch to give the drill bit a pilot to prevent wandering while drilling.
3. Drill the frame with a 10mm bit (3/8").
4. Deburr the hole to remove all the sharp metal burrs.

**Note:** A deburring tool was previously provided for safety recall D0C. This tool works well to remove these sharp burrs.

5. Using tape secure bolt and washer to the back of the frame as shown.

**Note:** Using the tape will prevent the bolt from spinning when torqueing the nut.

Part #	Part Name	Qty
90119-A0170	Bolt, Flange	2
90178-A0024	Nut	2

6. Install the frame seal and torque the nut to spec.

**Torque Spec: 18.5 N·m (14.0 ft-lbf)**

**4. INSTALL THE NEW FRONT SUSPENSION LOWER ARM (4WD, PRE-RUNNER ONLY)**

- a) Install the **NEW** front suspension lower arm with the **NEW** bolt, nut, **NEW** toe adjust cam, **NEW** No.2 toe adjust cam, **NEW** No.1 camber adjust cam and **NEW** No.2 camber adjust cam, then torque to spec.

**Torque Spec: 135 N-m (1377 kgf-cm, 100 ft-lbf)**

- b) Repeat the procedure on the opposite side.

**NEW Replacement Parts**

Part #	Part Name	Kit #	Qty
48068-04040	Arm Sub-Assy, Suspension LWR RH w/Bush	NA*	1
48069-04040	Arm Sub-Assy, Suspension LWR LH w/Bush	NA*	1
48190-60020	Cam Assy, Camber Adjust	5	2
48198-60011	Cam, Camber Adjust No. 2	5	2
48409-60020	Cam Sub- Assy, Toe Adjust	5	2
48452-35020	Plate, Toe Adjust, No. 2	5	2
90119-A0166	Bolt, w/ Washer	8	2

\*Individual Part(s)

4WD, Pre-Runner Only

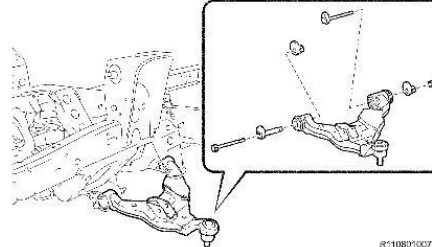

R1108010078

**NEW Replacement Parts (2WD Only)**

Part #	Part Name	Kit #	Qty
48304-04090	Bumper, Sub-Assy FR	NA*	2
48304-AD010	Spring**	NA*	2

\*Individual Part(s)

\*\*Only 1 part used, part number varies by vehicle type.

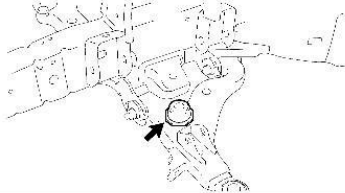

**NEW Replacement Parts (4WD, Pre-Runner Only)**

Part #	Part Name	Kit #	Qty
48304-04100	Bumper, Sub-Assy FR Spring	8	2



**5. INSTALL THE NEW FRONT SPRING BUMPER**

- a) Using the **SST 09922-10010-01**, install the **NEW** front spring bumpers and torque to spec.

**Torque Spec: 31 N-m (316 kgf-cm, 23 ft-lbf)**

- b) Repeat the procedure on the opposite side.

**6. INSTALL THE NEW REAR BRAKE TUBES**

- a) Install the **NEW** rear brake tubes with the **NEW** clamp(s).

**NEW Replacement Parts**

Part #	Part Name	Kit #	Qty
47325-*****	Tube, RR Brake, No.5**	NA*	1
47326-*****	Tube, RR Brake, No.6**	NA*	1
90469-A0004	Clamp (Regular Cab)	NA*	2
90469-A0004	Clamp (Access Cab)	NA*	3
90469-A0004	Clamp (Double Cab)	NA*	4
90949-A1006	Clamp	2	3

\*Individual Part(s)

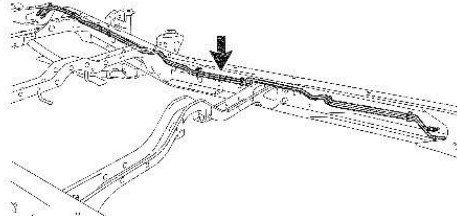

**NEW Replacement Parts**

Part #	Part Name	Kit #	Qty
77285-35760	Support, Fuel Return & Main Tube	1	1

Fuel Return and Main Tube Support

**7. REINSTALL THE NO. 2 CHARCOAL CANISTER PIPE**

- a) Install the **NEW** fuel return and main tube support.
- b) Reinstall the No.2 charcoal canister pipe.

**NEW Replacement Parts**

Part #	Part Name	Kit #	Qty
90119-A0169	Bolt, w/ Washer	2	4
51900-35410	Carrier Assy, Spare	NA*	1
81900-35420	Wheel**	NA*	1

\*Individual Part(s)  
\*\*Only 1 part used, part number varies by vehicle type.

**8. INSTALL THE **NEW** SPARE TIRE CARRIER ASSY**

- a) Install the **NEW** spare tire carrier assy with the 4 **NEW** bolts and torque to spec.

**Torque Spec: 20 N·m (204 kgf·cm, 15 ft·lbf)**

**9. INSTALL LEAF SPRINGS**

**4WD and PreRunner**

- a) Reinstall leaf springs and shackle and torque to spec.

**Torque Spec: 120 N·m (1224 kgf·cm, 89 ft·lbf)**

**2WD**

- b) Install the **NEW** rear leaf springs with the all **NEW** parts (shackle, bushings, bolts, washers and nuts) and torque to spec.

**Torque Spec: 120 N·m (1224 kgf·cm, 89 ft·lbf)**

Part #	Part Name	Kit #	Qty
04483-04080	Shackle Kit, RR Spring	2	2
90080-10138	Bolt, Flange	2	2
90178-A0050	Nut, Flange	2	2
94622-51400	Washer, Plain	1	2
Varies**	Spring Assy, RR RH	NA*	1
Varies**	Spring Assy, RR LH	NA*	1

- c) Repeat the procedure on the opposite side.

**NEW Replacement Parts**

**Rear Differential Assy**

Part #	Part Name	Kit #	Qty
90117-A0001	Bolt, U**	NA*	4
90117-A0002		NA*	4
90117-A0005		NA*	4
90178-A0050	Nut, Flange	2	8
90178-51400	Washer, Plain	1	8

*\*Individual Part(s)*

\*\*Only 1 part used, part number varies by vehicle type.

**Rear Shock Absorber Assy**

Part #	Part Name	Kit #	Qty
90117-A0010	Nut, Lock	2	2

**Rear Stabilizer Bar**

Part #	Part Name	Kit #	Qty
90119-08A91	Bolt, w/ Washer	NA*	4

*\*Individual Part(s)*

**10. REINSTALL THE FOLLOWING PARTS**

- Rear Differential Assy
  - Reinstall with the 4 **NEW** U-bolts (2WD), 2 spring seats, 2 spring bumpers (*If Equipped*), 8 **NEW** flange nuts and 8 **NEW** plain washers, then torque to spec.
  - **Torque Spec: 50 N·m (510 kgf·cm, 37 ft·lbf)**
- Rear Shock Absorber Assy
  - Reinstall rear shock absorber assy with the bolt, nut and washer. (*Lower side*)
  - **Torque Spec: Nut - 58 N·m (591 kgf·cm, 43 ft·lbf)**
  - Reinstall the 3 retainers, 2 cushions and **NEW** nut, then torque to spec. (*Upper side*)
  - **Torque Spec: Nut - 20 N·m (204 kgf·cm, 15 ft·lbf)**
  - Repeat the procedure on the opposite side.
- Rear Stabilizer Bar (*If Equipped*)
  - Reinstall with the 2 brackets and **NEW** 4 bolts, then torque to spec.
  - **Torque Spec: 27 N·m (275 kgf·cm, 20 ft·lbf)**
  - Reconnect the 2 stabilizer bar links with the 4 nuts, then torque to spec.
  - **Torque Spec: 65 N·m (663 kgf·cm, 48 ft·lbf)**

**NEW Replacement Parts**

Part #	Part Name	Kit #	Qty
47355-04020	Bracket, Flexible Hose, No. 2	2	1
90119-A0169	Bolt, W/ Washer	13 or NA*	2
90468-A0007	Clip	2	2

*\*Individual Part(s)*

**11. RECONNECT THE BRAKE HOSE**

- a) Install the **NEW** No.2 flexible hose bracket with the 2 **NEW** bolts.
- b) Reconnect the 2 brake hoses with the 2 **NEW** clips.
- c) Reconnect the No.5, No.6 rear brake tubes and torque to spec.

**Torque Spec:**  
**Flexible hose bracket - 29 N·m (296 kgf·cm, 21 ft·lbf)**  
**Rear brake tube - 15.2 N·m (155 kgf·cm, 11 ft·lbf)**

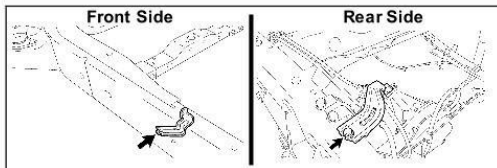
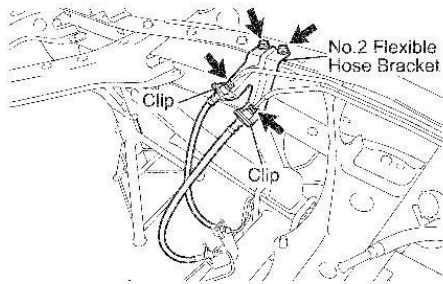

**12. REINSTALL THE HARNESS BRACKETS**

- a) Reinstall the 2 brackets with the 2 bolt and torque to spec.
- Torque Spec: 14 N·m (143 kgf·cm, 10 ft·lbf)**

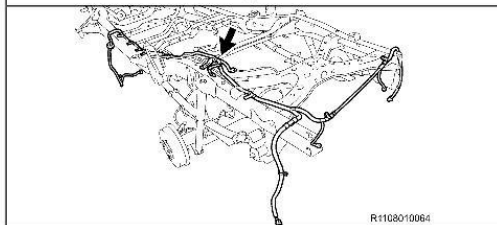

**13. REINSTALL THE FRAME WIRE HARNESS**

- a) Reconnect the clamps to install the frame wire harness.
- b) Reconnect the ground wire with the bolt and torque to spec.

**Torque Spec: 12.7 N·m (130 kgf·cm, 9 ft·lbf)**

**NOTE: The number of wire harness clamps will differ depending on the vehicle spec.**

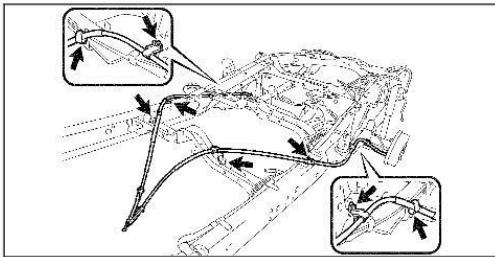

**14. REINSTALL THE PARKING BRAKE CABLES**

- a) Reinstall the 2 parking brake cables with the 8 bolts, then torque to spec.

**Torque Spec: 12.5 N·m (127 kgf·cm, 9 ft·lbf)**

**NEW Replacement Parts**

Part #	Part Name	Kit #	Qty
90171-A0005	Nut, Castle	2	2
95381-03230	Pin, Cotter	4-5	2

**15. REINSTALL THE LOWER BALL JOINT**

- a) Reinstall the lower ball joint with the **NEW** nut and torque to spec.

**Torque Spec: 160 N·m (1632 kgf·cm, 118 ft·lbf)**

- b) Install the **NEW** cotter pin.
- c) Repeat the procedure on the opposite side.

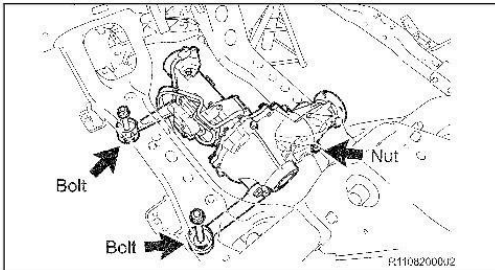

**16. REINSTALL FRONT DIFFERENTIAL CARRIER (4WD ONLY)**

- a) Reinstall the front differential carrier with the 2 bolts, 4 stoppers and 3 nuts, then torque to spec.

**Torque Spec: Except TMMTX Made**  
**Bolt - 137.3 N·m (1400 kgf·cm, 101 ft·lbf)**  
**Nut - 87.2 N·m (889 kgf·cm, 64 ft·lbf)**

**Torque Spec: TMMTX Made**  
**Bolt - 128.5 N·m (1310 kgf·cm, 95 ft·lbf)**  
**Nut - 81.5 N·m (831 kgf·cm, 60 ft·lbf)**

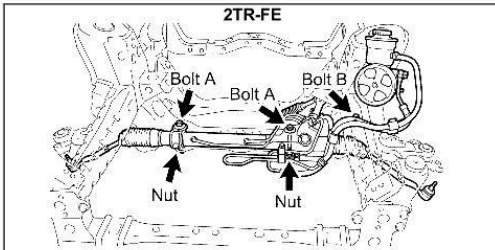

**17. REINSTALL THE POWER STEERING LINK ASSY W/ POWER STEERING VANE PUMP**

- a) Reinstall the power steering link assy w/ power steering vane pump with the bolts and nuts, then torque to spec.

**Torque Spec:**  
**Bolt A - 92 N·m (938 kgf·cm, 68 ft·lbf)**  
**Bolt B - 28 N·m (286 kgf·cm, 21 ft·lbf)**

**NOTE:**

- When reinstalling the power steering link with the pump, have one person support the power steering link and the other support the pump.
- Keep the power steering pump reservoir upright to prevent the fluid from leaking out.

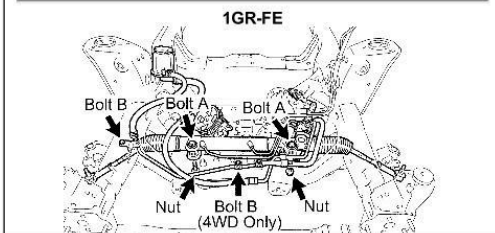

**18. RECONNECT THE FRONT DIFFERENTIAL BREATHER TUBE (4WD ONLY)**

- a) Reconnect the front differential breather tube with the bolt and 2 clamps, then torque to spec.

**Torque Spec: 12.7 N·m (130 kgf·cm, 9 ft·lbf)**

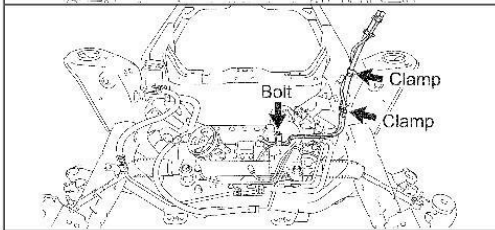

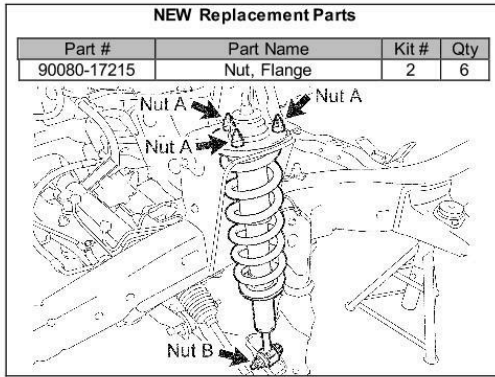

**19. REINSTALL THE FRONT SHOCK ABSORBER ASSY**

- a) Install the 3 **NEW** nuts (A) and torque to spec.
- b) Reinstall the front shock absorber assy with the bolt and nut (B), then torque to spec.

**Torque Spec:**

**Nut A - 64 N·m (653 kgf·cm, 47 ft·lbf)**

**Nut B - 83 N·m (846 kgf·cm, 61 ft·lbf)**

- c) Repeat the procedure on the opposite side.

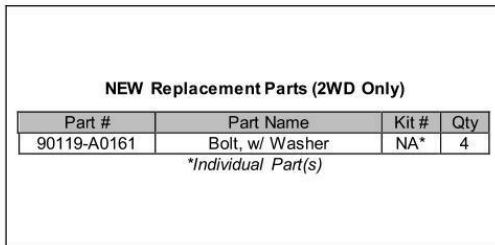

**20. REINSTALL THE FRONT STABILIZER BAR**

- a) Reinstall the stabilizer bar with 2 brackets and 4 **NEW** bolts, then torque to spec. *(2WD Only)*
- b) Reinstall the stabilizer bar with 2 brackets and 4 bolts, then torque to spec. *(4WD, Pre-Runner Only)*

**Torque Spec:**

**2WD - 21 N·m (214 kgf·cm, 15 ft·lbf)**

**4WD, Pre-Runner - 40 N·m (408 kgf·cm, 30 ft·lbf)**

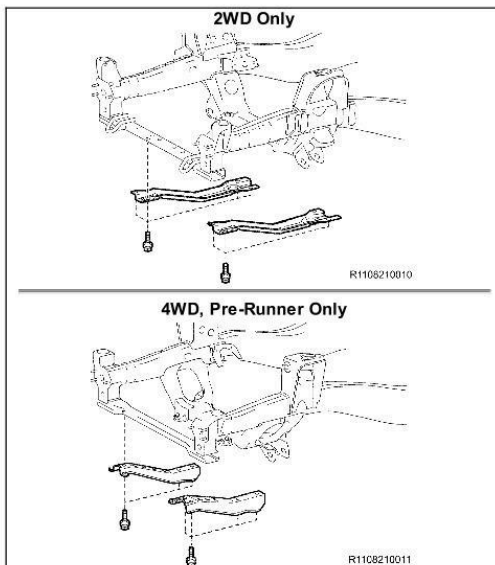

**21. REINSTALL THE SUSPENSION MEMBER BRACE SUB-ASSY**

- a) Reinstall the suspension member brace sub-assy with 8 bolts *(2WD Only)* or 7 bolts *(4WD, Pre-Runner Only)*, then torque to spec.

**Torque Spec: 45 N·m (459 kgf·cm, 33 ft·lbf)**

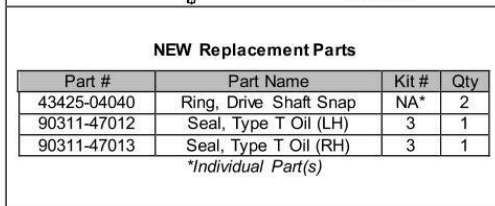

**22. REINSTALL THE FRONT DRIVE SHAFT ASSY (4WD ONLY)**

- a) Install a **NEW** snap ring.
- b) Reinstall the front drive shaft assy.
- c) Repeat the procedure on the opposite side.

**NOTE:**

- **Be careful not to damage the dust cover and oil seal.**
- **If the oil seal is damaged, replace the **NEW** parts.**

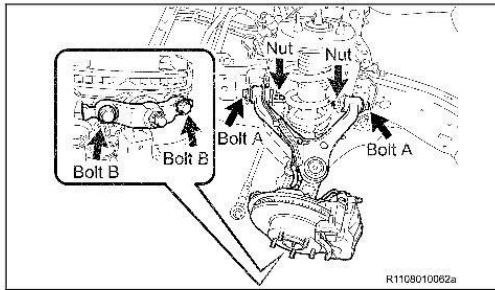

**23. REINSTALL THE FRONT SUSPENSION UPPER ARM AND STEERING KNUCKLE ASSY (2WD ONLY)**

- a) Reinstall the front suspension upper arm w/ steering knuckle with the 2 bolts (A), 2 nuts and 2 washers, then torque to spec.

**Torque Spec: Bolt A - 82 N·m (836 kgf·cm, 60 ft·lbf)**

- b) Reinstall the 2 bolts (B), then torque to spec.

**Torque Spec: Bolt B - 160 N·m (1632 kgf·cm, 118 ft·lbf)**

- c) Repeat the procedure on the opposite side.

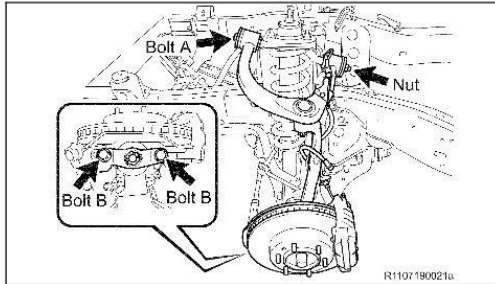

**24. REINSTALL THE FRONT SUSPENSION UPPER ARM AND STEERING KNUCKLE ASSY (4WD, PRE-RUNNER ONLY)**

- a) Reinstall the front suspension upper arm w/ steering knuckle with the bolt (A), nut and 2 washers, then torque to spec.

**Torque Spec: Nut - 115 N·m (1173 kgf·cm, 85 ft·lbf)**

- b) Reinstall the 2 bolts (B), then torque to spec.

**Torque Spec: Bolt B - 160 N·m (1632 kgf·cm, 118 ft·lbf)**

- c) Repeat the procedure on the opposite side.

**25. REINSTALL THE FOLLOWING PARTS**

- Front Stabilizer Link (*2WD Only*)
  - Reinstall with 2 retainers, 2 cushions and nut, torque to spec.
  - **Torque Spec: 19 N·m (194 kgf·cm, 14 ft·lbf)**
  - Reinstall the nut, then torque to spec.
  - **Torque Spec: 69 N·m (704 kgf·cm, 51 ft·lbf)**
  - Repeat the procedure on the opposite side.
- Front Stabilizer Link (*4WD, Pre-Runner Only*)
  - Reinstall front stabilizer link with 2 nuts, torque to spec.
  - **Torque Spec: 70 N·m (714 kgf·cm, 52 ft·lbf)**
  - Repeat the procedure on the opposite side.
- Tie Rod End
  - Reinstall tie rod end with nut and torque to spec.
  - **Torque Spec:**
    - 2WD - 49 N·m (500 kgf·cm, 36 ft·lbf)**
    - 4WD, Pre-Runner - 91 N·m (928 kgf·cm, 67 ft·lbf)**
  - Install the **NEW** cotter pin.
  - Repeat the procedure on the opposite side.
- Front Axle Shaft Nut (*4WD Only*)
  - Temporarily reinstall the front axle nut.
  - Nut will be tightened when the vehicle is completed.
  - Repeat the procedure on the opposite side.

**NEW Replacement Parts**

**Tie Rod End**

Part #	Part Name	Kit #	Qty
95381-03025		4	2
95381-03225	Pin, Cotter**	5	2

\*\*Only 1 part used, part number varies by vehicle type.

**NEW Replacement Parts**

Part #	Part Name	Kit #	Qty
47314-04140	Tube, FR Brake No. 4	12	1
47316-04140	Tube, FR Brake No. 6	12	1
90119-A0169	Bolt, w/ Washer	NA*	2
90412-10247	Way, 2	1	2

\*Individual Part(s)

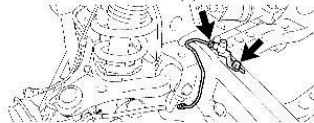

**26. INSTALL THE NEW FRONT BRAKE TUBE AND NEW WAY (2WD ONLY)**

- a) Temporarily install the **NEW** front brake tube and **NEW** way.
- b) Install the **NEW** bolt to the **NEW** front way and torque to spec.

**Torque Spec: 32 N·m (326 kgf·cm, 24 ft·lbf)**

- c) Repeat the procedure on the opposite side.

**NEW Replacement Parts**

Part #	Part Name	Kit #	Qty
47314-04150	Tube, FR Brake No. 4	12	1
47316-04150	Tube, FR Brake No. 6	12	1
90119-A0169	Bolt, w/ Washer	13	2
90412-10247	Way, 2	1	2

\*Individual Part(s)

**27. INSTALL THE NEW FRONT BRAKE TUBE AND NEW WAY (4WD, Pre-Runner ONLY)**

- a) Temporarily install the **NEW** front brake tube and **NEW** way.
- b) Install the **NEW** bolt to the **NEW** front way and torque to spec.

**Torque Spec: 32 N·m (326 kgf·cm, 24 ft·lbf)**

- c) Repeat the procedure on the opposite side.

**NEW Replacement Parts**

Part #	Part Name	Kit #	Qty
47351-04030	Bracket, Flexible Hose, RH	12	1
47352-04030	Bracket, Flexible Hose, LH	12	1
90119-A0169	Bolt, w/ Washer	NA*	4
90468-A0007	Clip	2	2

\*Individual Part(s)

**28. REINSTALL THE FRONT BRAKE HOSE (2WD ONLY)**

- a) Reinstall the flexible hose bracket with the **NEW** bolt and torque to spec.

**Torque Spec: 32 N·m (326 kgf·cm, 24 ft·lbf)**

- b) Reconnect the front brake hose with a **NEW** clip.
- c) Reconnect the front brake tube and torque to spec.

**Torque Spec: 15.2 N·m (155 kgf·cm, 11 ft·lbf)**

- d) Reinstall the **NEW** bolt and torque to spec.

**Torque Spec: 32 N·m (326 kgf·cm, 24 ft·lbf)**

- e) Repeat the procedure on the opposite side.

**NEW Replacement Parts**

Part #	Part Name	Kit #	Qty
47353-04010	Bracket, Flexible Hose, No. 3	13	1
47354-04010	Bracket, Flexible Hose, NO. 4	13	1
90119-A0169	Bolt, w/ Washer	13	4
90468-A0007	Clip	2	2

**29. REINSTALL THE FRONT BRAKE HOSE (4WD, PRE-RUNNER ONLY)**

- a) Reinstall the flexible hose bracket with the bolt and torque to spec.

**Torque Spec: 32 N·m (326 kgf·cm, 24 ft·lbf)**

- b) Reconnect the front brake hose with a **NEW** clip.
- c) Reconnect the front brake tube and torque to spec.

**Torque Spec: 15.2 N·m (155 kgf·cm, 11 ft·lbf)**

- d) Repeat the procedure on the opposite side.

**NEW Replacement Parts**

Part #	Part Name	Kit #	Qty
89516-04010	Wire, Skid Control Sensor RH	NA*	1
89516-04020	Wire, Skid Control Sensor LH	NA*	1

\*Individual Part(s)

**30. RECONNECT THE FRONT SKID CONTROL SENSOR WIRE HARNESS (2WD ONLY)**

- a) Reconnect the clamp.
- b) Reinstall the front skid control sensor wire harness with bolt and torque to spec.

**Torque Spec: 5.0 N·m (51 kgf·cm, 44 in·lbf)**

- c) Repeat the procedure on the opposite side.

**NOTE: If the front skid control sensor wire harness and clamp are damaged, replace the **NEW** parts.**

NEW Replacement Parts			
Part #	Part Name	Kit #	Qty
89516-04040	Wire, Skid Control Sensor RH	NA*	1
89516-04090	Wire, Skid Control Sensor LH	NA*	1

\*Individual Part(s)

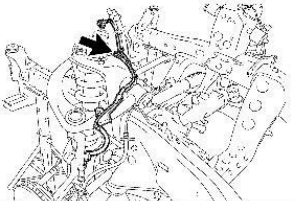

**31. RECONNECT THE FRONT SKID CONTROL SENSOR WIRE HARNESS (4WD, PRE-RUNNER ONLY)**

- a) Reinstall the front skid control sensor wire harness with bolt and torque to spec.

**Torque Spec: 12.5 N·m (127 kgf·cm, 9 ft·lbf)**

- b) Repeat the procedure on the opposite side.

**NOTE: If the front skid control sensor wire harness and clamp are damaged, replace the NEW parts.**

**32. REINSTALL THE WHEELS**

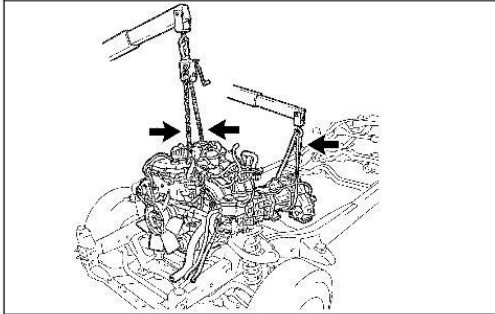

**33. REINSTALL THE ENGINE AND TRANSMISSION ASSY**

- a) Reinstall engine and transmission assy.

**NOTE:**

- Use 2 engine hoists/cranes to lift engine & trans assy.
- DO NOT use 1 engine hoist/crane to lift the engine & trans assy, the unbalanced weight may lead to an accident or injury.
- ONLY use engine hoists/cranes that can properly support the weight of the engine & trans.
- Carefully adjust the 2 engine hoists/cranes used so that the engine & trans assy is balanced.

- b) Attach the engine mounts with the 4 NEW bolts and 4 NEW nuts, then torque to spec.

**Torque Spec: 38 N·m (387 kgf·cm, 28 ft·lbf)**

NEW Replacement Parts			
Part #	Part Name	Kit #	Qty
90179-10201	Nut	1	4
90910-03001	Bolt, Engine Mount	1	4

LH Side

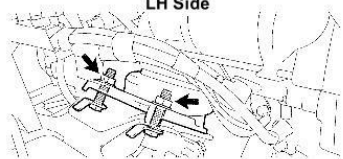

RH Side

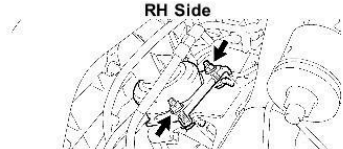

NEW Replacement Parts			
Part #	Part Name	Kit #	Qty
91671-80814	Bolt, Flange w/ Washer	1	4

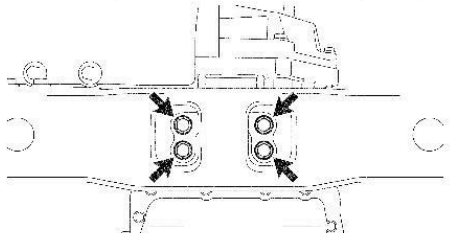

- c) Attach the transmission mount with 4 NEW bolts and torque to spec.

**Torque Spec: 18.5 N·m (189 kgf·cm, 14 ft·lbf)**

- d) Remove the bolt(s) and the engine hangers.  
 e) Reinstall the items/parts that were removed during the engine and transmission assy removal.

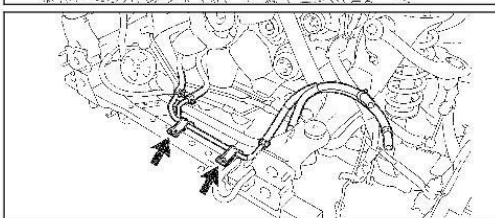
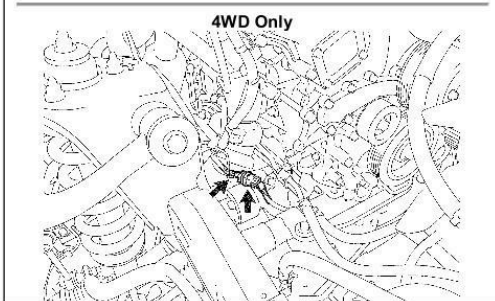
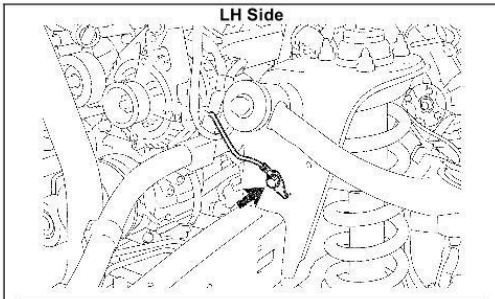

- f) Reinstall the bolt and reconnect the ground wire. *(LH Side)*  
**Torque Spec: 12.7 N·m (130 kgf·cm, 9 ft·lbf)**
- g) Reconnect the connector and clamp. *(4WD Only)*

**34. RECONNECT THE OIL COOLER TUBE (AUTO TRANS ONLY)**

- a) Reconnect the oil cooler tube with the 2 bolts and torque to spec.  
**Torque Spec: 28 N·m (286 kgf·cm, 21 ft·lbf)**

**35. REINSTALL THE INTAKE AIR SURGE TANK (1GR-FE ONLY)**

- a) Install a **NEW** gasket onto the intake air surge tank.
- b) Using a 8mm hexagon socket, reinstall the intake air surge tank with the 4 bolts and torque to spec.  
**Torque Spec: 28 N·m (286 kgf·cm, 21 ft·lbf)**
- c) Reinstall the 2 intake air surge tank nuts and torque to spec.  
**Torque Spec: 28 N·m (286 kgf·cm, 21 ft·lbf)**
- d) Reinstall the 2 surge tank stays with the 4 bolts, then torque to spec.  
**Torque Spec: 21 N·m (214 kgf·cm, 15 ft·lbf)**
- e) Reinstall oil baffle plate with the bolt and torque to spec.  
**Torque Spec: 9.0 N·m (92 kgf·cm, 80 in·lbf)**
- f) Reinstall the throttle body bracket with the 2 bolts, then torque to spec.  
**Torque Spec: 21 N·m (214 kgf·cm, 15 ft·lbf)**
- g) Reconnect the 3 wire harness clamps and hose clamp.
- h) Reconnect the throttle body w/ motor connector.
- i) Reconnect the 2 VSV connectors.
- j) Reconnect the ventilation hose.
- k) Reconnect the fuel vapor feed hose.
- l) Reconnect the 2 water by-pass hoses.

**NEW Replacement Parts**

Part #	Part Name	Kit #	Qty
17176-0P010	Gasket, Air Surge Tank INT Manifold	6	1

**36. REINSTALL THE INTAKE AIR CONNECTOR (2TR-FE ONLY)**

- a) Reinstall the intake air connector with the 3 bolts, then torque to spec.

**Torque Spec: 8.0 N·m (82 kgf·cm, 71 in·lbf)**

- b) Tighten the hose clamp bolts.
- c) Reconnect the vacuum hose.
- d) Reconnect the No.2 ventilation hose.
- e) Reconnect the vacuum hose.
- f) Reconnect the wire harness clamp.
- g) Reconnect the pressure sensor connector.

**37. REINSTALL THE POWER STEERING PUMP ASSY**

- a) Reinstall the bolt and reconnect the ground wire and torque to spec. (1GR-FE Only)

**Torque Spec: 8.0 N·m (82kgf·cm, 71 in·lbf)**

- b) Reinstall the power steering vane pump with the 2 bolts, then torque to spec.

**Torque Spec: 21 N·m (214 kgf·cm, 15 ft·lbf)**

- c) Reconnect the connector.
- d) Reconnect the clamp. (1GR-FE Only)

**38. REINSTALL THE FAN AND GENERATOR V-BELT**

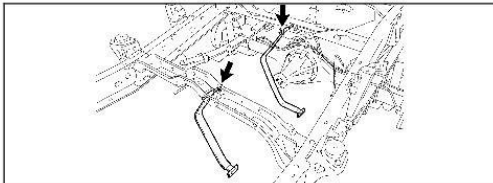

**NEW Replacement Parts**

Part #	Part Name	Kit #	Qty
90080-11376	Bolt, W/ Washer	2	2

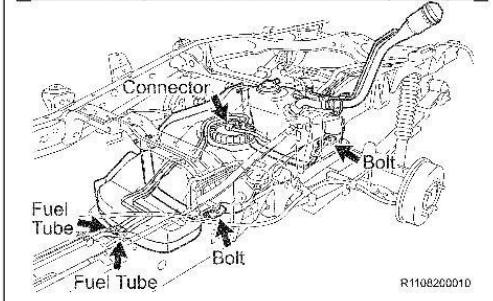

R110820010

**39. REINSTALL THE FUEL TANK STRAPS**

- a) Reinstall the fuel tank straps with the 2 pins and 2 clips.

**40. REINSTALL THE FUEL TANK**

- a) Reinstall the fuel tank with the 2 **NEW** bolts and torque to spec.

**Torque Spec: 62 N·m (632 kgf·cm, 46 ft·lbf)**

- b) Reinstall the 2 fuel tubes.
- c) Reconnect the connector.

**41. REINSTALL THE NO.2 FUEL TANK PROTECTOR (IF EQUIPPED)**

**NEW Replacement Parts**

Part #	Part Name	Kit #	Qty
90179-08241	Nut	NA*	4
*Individual Part(s)			

**42. REINSTALL THE NO.1 FUEL TANK PROTECTOR ASSY (IF EQUIPPED)**

- a) Reinstall the No.1 fuel tank protector assy with the 4 **NEW** nuts and torque to spec.

**Torque Spec: 20 N·m (204 kgf·cm, 15 ft·lbf)**

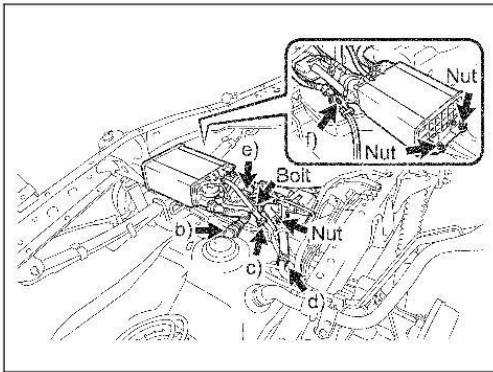

**43. REINSTALL THE CHARCOAL CANISTER ASSY**

- a) Reinstall the charcoal canister assy with the bolt and 3 nuts, then torque to spec.
- b) Reconnect the fuel tank vent hose.
- c) Reconnect the fuel hose.
- d) Reconnect the main tube support and reconnect the filter hose.
- e) Reconnect the connector.
- f) Reinstall the bolt and reconnect the skid control sensor wire and torque to spec.

**Torque Spec: 20 N·m (204 kgf·cm, 15 ft·lbf)**

**Torque Spec: 14 N·m (143 kgf·cm, 10 ft·lbf)**

**NEW Replacement Parts**

Part #	Part Name	Kit #	Qty
90080-17187	Nut, Lock	6	4
90080-43036	Gasket, Exhaust Pipe	6	2
90126-A0011	Stud, Hex lobular	6	4

R1107190013

**44. REINSTALL THE EXHAUST SYSTEM (1GR-FE ONLY)**

- a) Install the 2 **NEW** exhaust pipe gaskets.
- b) Reinstall the front exhaust pipe assy and 2 exhaust pipe supports.
- c) Install the 4 **NEW** nuts and torque to spec.
- d) Reconnect the 2 oxygen sensor connectors.

**Torque Spec: 54.3 N·m (554 kgf·cm, 40 ft·lbf)**

**NOTE: If the stud bolt is damaged, replace the **NEW** parts.**

**NEW Replacement Parts**

Part #	Part Name	Kit #	Qty
17451-0A010	Gasket, Exhaust Pipe	2	1
90080-10291	Bolt	6	2

R1107190014

- e) Install the **NEW** exhaust pipe gasket.
- f) Reinstall the center exhaust tail pipe and 4 exhaust pipe supports.
- g) Install the 2 **NEW** bolts and 2 springs, then torque to spec.

**Torque Spec: 43 N·m (438 kgf·cm, 32 ft·lbf)**

**45. REINSTALL THE EXHAUST SYSTEM (2TR-FE ONLY)**

**NEW Replacement Parts**

Part #	Part Name	Kit #	Qty
17451-0A010	Gasket, Exhaust Pipe	2	1
90080-10064	Bolt, Flange	7	2
90080-10291	Bolt, Flange	7	2
90080-43033	Gasket, Exhaust Pipe	7	1
90177-A0004	Nut, Lock	7	2

- a) Install the **NEW** exhaust pipe gasket.
- b) Reinstall the front exhaust pipe assy and exhaust pipe support.
- c) Install the 2 **NEW** bolts and 2 springs, then torque to spec.

**Torque Spec: 43 N·m (438 kgf·cm, 32 ft·lbf)**

- d) Reconnect the 2 oxygen sensor connectors and 2 wire harness clamps.
- e) Install the **NEW** exhaust pipe gasket.
- f) Reinstall the center exhaust tail pipe and 4 exhaust pipe supports.
- g) Install the 2 **NEW** bolts and torque to spec.

**Torque Spec: 48 N·m (489 kgf·cm, 35 ft·lbf)**

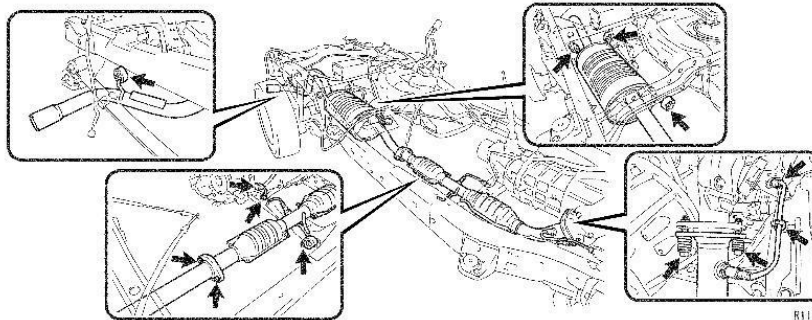

R1107180015

**NEW Replacement Parts**

Part #	Part Name	Kit #	Qty
90080-11180	Bolt, w/ Washer	6	2

**46. REINSTALL THE EXHAUST PIPE STOPPER BRACKET (IF EQUIPPED)**

- a) Reinstall the exhaust pipe stopper bracket with the 2 bolts and torque to spec.

**Torque Spec: 19 N·m (194 kgf·cm, 14 ft·lbf)**

**47. REINSTALL THE REAR PROPELLER SHAFT ASSY**

- a) Remove the SST. (*2WD Only*)
- b) Referencing the matchmarks, reinstall the propeller shaft assy to the the transmission / transfer case.
- c) Reinstall the 4 washers and 4 nuts, then torque to spec. (*4WD Only*)

**Torque Spec: 88.2 N·m (899 kgf·cm, 65 ft·lbf)**

- d) Reinstall the center support bearing to the frame as shown in the illustration with 2 washer and 2 bolts, then torque to spec. (*3-Joint Type Only*)

**Torque Spec: 36.2 N·m (369 kgf·cm, 27 ft·lbf)**

- e) Referencing the matchmarks, reinstall the propeller shaft assy to the rear differential with 4 bolts, 4 washers and 4 nuts, then torque to spec.

**Torque Spec: 88.2 N·m (899 kgf·cm, 65 ft·lbf)**

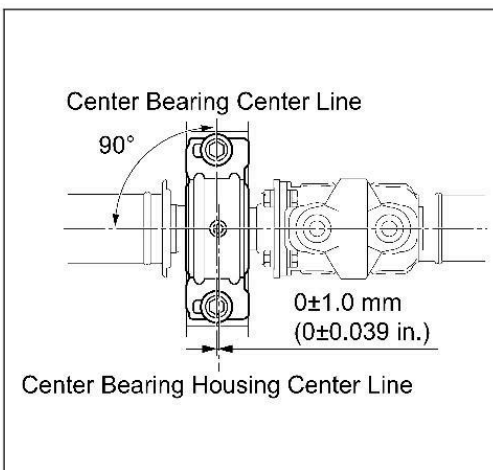

**48. REINSTALL THE FRONT PROPELLER SHAFT ASSY**

- a) Referencing the matchmarks, install the front propeller shaft assy to the transfer case and the front differential with 4 bolts, 8 washers and 8 nuts, then torque to spec.

**Torque Spec: 88.2 N·m (899 kgf·cm, 65 ft·lbf)**

**49. REINSTALL THE FOLLOWING PARTS**

- Spare Tire
- Wheels

**50. REMOVE THE FRAME FROM THE LIFT**

- a) Remove the ratcheting tie down strap from the frame.  
b) Lower the frame to the ground.

**H. REINSTALL THE CAB BODY ASSY**

**Before lowering the cab assembly ensure that you install the NEW brakelines onto the bulk head.**

NEW Replacement Parts			
Part #	Part Name	Kit #	Qty
47313-04190	Tube, FR Brake No. 3**	10	1
47313-04200		11	1
47315-04160		10	1
47315-04170	Tube, FR Brake No. 5**	11	1
47323-04160		NA*	1
47323-04170	Tube, RR Brake No. 3	11	1
47324-04120	Tube, RR Brake No. 4	NA*	1
47324-04130	Tube, RR Brake No. 4	11	1

\*Individual Part(s)  
\*\*Only 1 part used, part number varies by vehicle type.

**1. INSTALL THE NEW ENGINE COMPARTMENT BRAKE TUBES**

- a) Install the **NEW** No.3 and **NEW** No.5 front brake tubes.  
b) Install the **NEW** No.3 and **NEW** No.4 rear brake tubes.  
c) Torque all brake tubes to spec.

**Torque Spec: 15.2 N·m (155 kgf·cm, 11 ft·lbf)**

**2. REINSTALL THE CAB BODY ASSEMBLY**

- a) Raise the cab assy high enough so that the top of the engine clears the lowest point of the cab.
- b) Push the frame under the cab assy and line the tires up with the alignment marks.
- c) Lower the cab assy slowly, making sure it does not interfere with anything.
- d) Adjust the vehicle's frame as needed to align the cab mounts with the cab assy bolts.
- e) Once the cab assy is set on the mounts, secure it to the frame with 6 bolts, 6 nuts, 6 washers and torque to spec.

**Torque Spec:**

**No.1 - 37.5 N·m (382 kgf·cm, 28 ft·lbf)**

**No.2, No.3 - 45 N·m (459 kgf·cm, 33 ft·lbf)**

**NOTE:**

- **DO NOT** work directly underneath the vehicle when pushing the frame under the cab assy.
- **Slowly** lower the cab assy making sure the wire harness, steering shaft & hoses don't interfere.
- **With 2 to 3 people** checking for interference, slowly lower the cab body assembly to the frame.

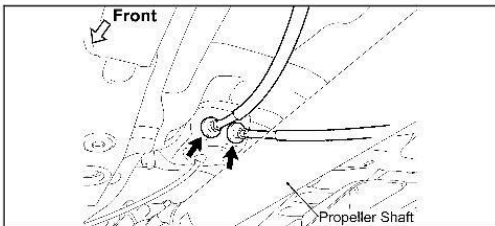
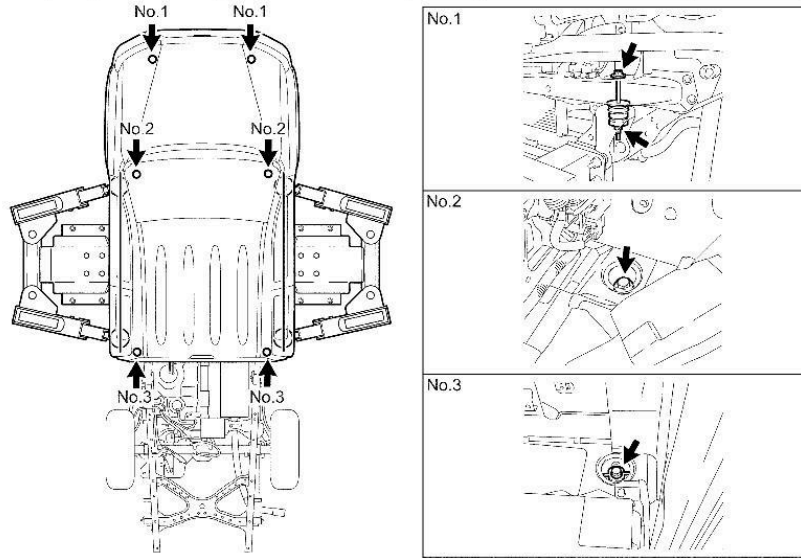

**3. RECONNECT THE PARKING BRAKE CABLE**

NEW Replacement Parts			
Part #	Part Name	Kit #	Qty
90412-10248	Way, 2	2	1
90119-A0169	Bolt, w/ Washer	13 or NA*	1

\*Individual Part(s)

**4. RECONNECT THE REAR BRAKE TUBES**

- a) Temporarily install the 4 rear brake tubes and **NEW** 2 way.
- b) Install the **NEW** bolt to the 2 way and torque to spec.

**Torque Spec: 32 N·m (326 kgf·cm, 24 ft·lbf)**

- c) Reconnect the 4 rear brake tubes and torque to spec.

**Torque Spec: 15.2 N·m (155 kgf·cm, 11 ft·lbf)**

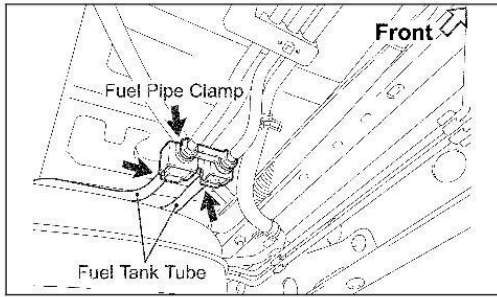

**5. RECONNECT THE FUEL TANK TUBES**

- a) Reconnect the 2 fuel tank tubes.
- b) Reinstall the fuel pipe clamp.

**NOTE:**

- Align the connector with the pipe, and push into the connector until the connector makes a "click" sound. If the connection is tight, apply a little amount of fresh engine oil on the tip of the pipe.
- Ensure the pipe and the connector are securely connected by pulling them.

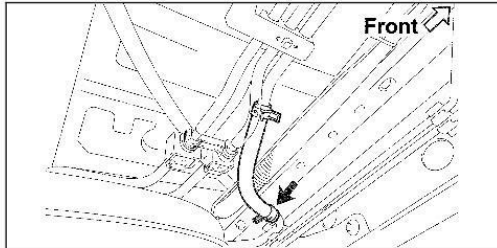

**6. RECONNECT THE NO.2 FUEL HOSE**

- a) Reconnect the No.2 fuel hose with the clip

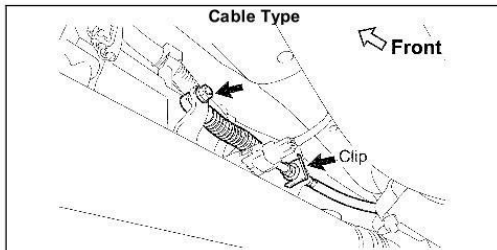

**7. RECONNECT THE SHIFT CABLE (AUTO TRANS ONLY)**

**Cable Type:**

- a) Reconnect the shift cable with the nut and torque to spec.

**Torque Spec: 14 N·m (143 kgf·cm, 10 ft·lbf)**

- b) Reinstall the clip.

**Rod Type:**

- c) Reconnect the shift cable with the **NEW** pin and **NEW** clip.

NEW Replacement Parts (Rod Type)			
Part #	Part Name	Kit #	Qty
90240-08054	Pin, W/ Hole	NA*	1
90468-14033	Clip	NA*	1

\*Individual Part(s)

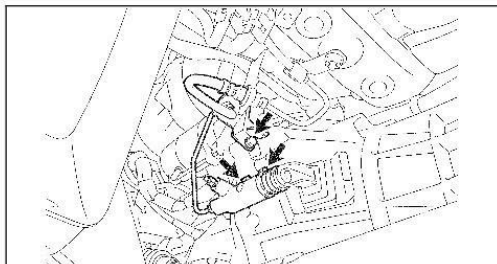

**8. CONNECT THE CLUTCH RELEASE CYLINDER ASSY (2TR-FE MANUAL TRANS ONLY)**

- a) Reconnect the clutch release cylinder with the 2 bolts and torque to spec.

**Torque Spec: 11.8 N·m (120 kgf·cm, 9 ft·lbf)**

- b) Reconnect the clutch hose with the bolt and torque to spec.

**Torque Spec: 37 N·m (377 kgf·cm, 27 ft·lbf)**

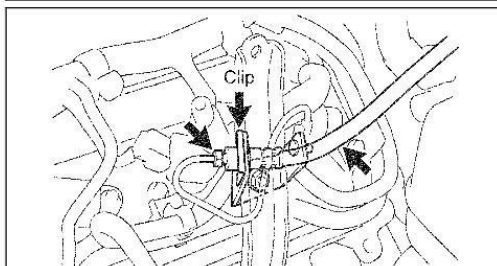

**9. RECONNECT THE NO.1 CLUTCH HOSE (1GR-FE MANUAL TRANS ONLY)**

- a) Reconnect the clutch hose with the clip.
- b) Reconnect the clutch release cylinder tube to the clutch hose.

**Torque Spec: 15.2 N·m (155 kgf·cm, 11 ft·lbf)**

**NEW Replacement Parts**

Part #	Part Name	Kit #	Qty
90080-11555	Bolt, w/ Washer	2	2

The diagram shows the steering yoke assembly with two bolts labeled Bolt A and Bolt B. Matchmarks are indicated on the control valve shaft area.

**10. RECONNECT THE STEERING SLIDING YOKE**

- a) Make sure the front wheels are in a straight-ahead position and the steering wheel is centered.
- b) Referencing the match marks, connect the steering sliding yoke to the control valve shaft with the **NEW** bolt (B).
- c) Remove bolt (A) and install the **NEW** bolt (A).
- d) Torque all bolts to spec.

**Torque Spec: 35 N·m (357 kgf·cm, 26 ft·lbf)**

- e) Disconnect the seat belt that is holding the steering wheel.

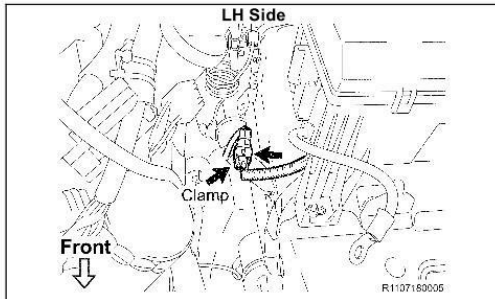

**11. RECONNECT THE FRONT SKID CONTROL SENSOR WIRE HARNESS**

- a) Reconnect the harness clamp and front skid control sensor connector.
- b) Repeat the procedure on the opposite side.

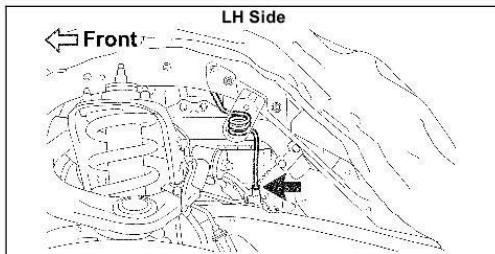
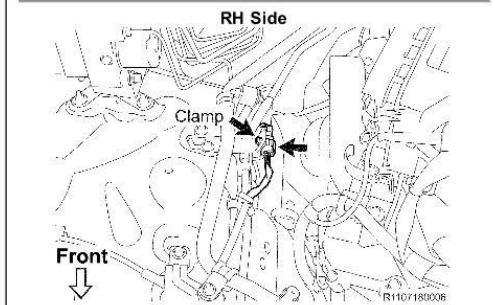

**12. RECONNECT THE FRONT BRAKE TUBES**

- a) Reconnect the front brake tube and torque to spec.

**Torque Spec: 15.2 N·m (155 kgf·cm, 11 ft·lbf)**

- b) Repeat the procedure on the opposite side.

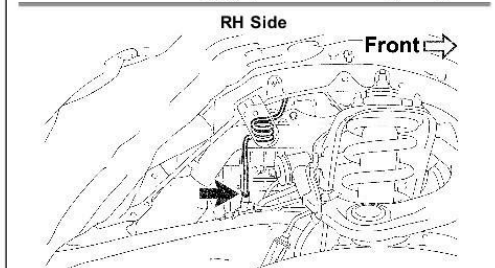

**NEW Replacement Parts**

Part #	Part Name	Kit #	Qty
90210-A0002	Washer, Seal	2	1
90210-A0004		2	1

**13. RECONNECT THE AIR CONDITIONING DISCHARGE AND SUCTION HOSES TO THE COMPRESSOR**

- a) Install a **NEW** o-ring to the A/C discharge and suction hoses.
- b) Reconnect the A/C discharge and suction hoses to the compressor, then torque to spec.

**Torque Spec: 19 N·m (194 kgf·cm, 14 ft·lbf)**

- c) Reconnect the cooler bracket with the bolt and torque to spec.

**Torque Spec: 7.5 N·m (76 kgf·cm, 66 in·lbf)**

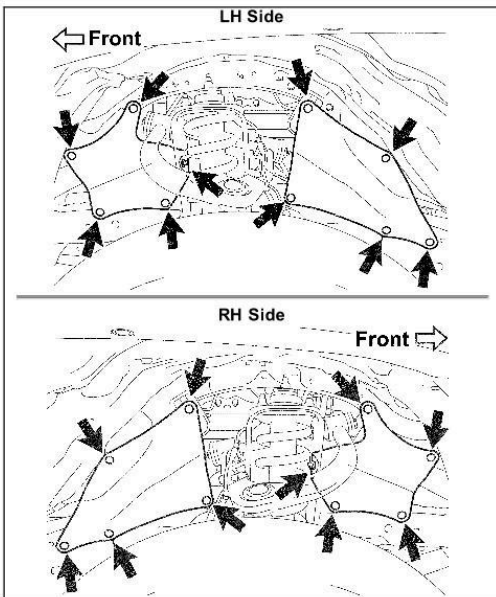

**14. REINSTALL THE FRONT FENDER APRON SEAL**

**4WD, Pre-Runner Only (Shown):**

- a) Reinstall the 4 front fender apron seals with the 20 clips.

**2WD Only:**

- b) Reinstall the 4 front fender apron seals with the 22 clips.

**15. RECONNECT THE WATER / HEATER HOSES, ENGINE SIDE**

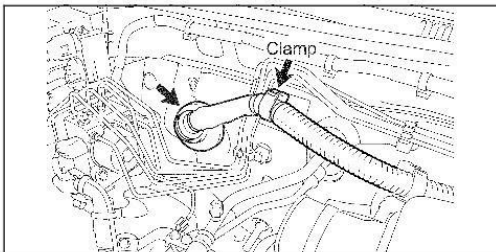

**16. RECONNECT THE ENGINE WIRE HARNES**

- a) Reinstall the engine wire harness container to the cowl panel.
- b) Reconnect the clamp.

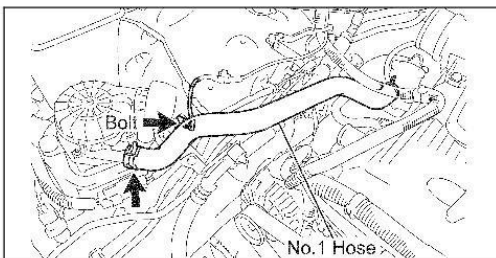

**17. RECONNECT THE NO.1 HOSE (2TR-FE ONLY)**

- a) Reconnect the No.1 hose.

**18. RECONNECT THE GROUND WIRE (2TR-FE ONLY)**

- a) Reconnect the ground wire with the bolt.

**Torque Spec: 8.3 N·m (85 kgf·cm, 73 in·lbf)**

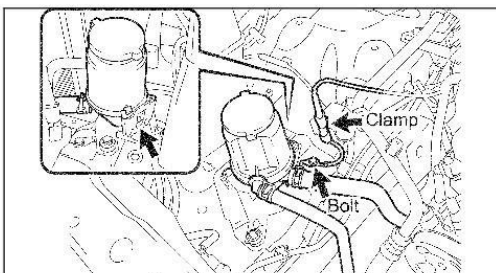

#### 19. RECONNECT THE POWER STEERING PUMP RESERVOIR ASSY (1GR-FE ONLY)

- Reconnect the power steering pump reservoir assy.

#### 20. RECONNECT THE GROUND WIRE (1GR-FE ONLY)

- Reconnect the ground wire with the bolt.
- Reconnect the clamp.

**Torque Spec: 8.3 N·m (85 kgf·cm, 73 in·lbf)**

**NEW Replacement Parts**

Part #	Part Name	Kit #	Qty
90069-08019	Ring, O	2	1

#### 21. REINSTALL THE FAN SHROUD

#### 22. REINSTALL THE RADIATOR

- Install the **NEW** o-ring to the drain plug.
- Tighten the radiator drain plug.
- Reinstall the radiator with 4 bolts and torque to spec.

**Torque Spec: 18 N·m (184 kgf·cm, 13 ft·lbf)**

- Reinstall the automatic transmission cooler lines (*Auto Trans Only*).
- Reinstall the fan shroud with the 2 bolts.

**Torque Spec: 5.0 N·m (51 kgf·cm, 44 in·lbf)**

#### 23. REINSTALL THE SUPPORT TO FRAME SEAL

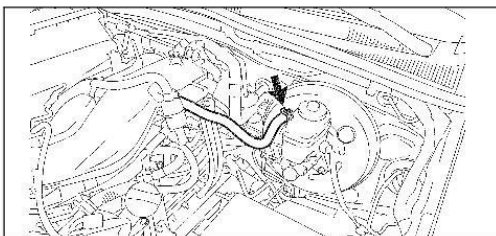

#### 24. RECONNECT THE VACUUM HOSE

- Reconnect the vacuum hose.

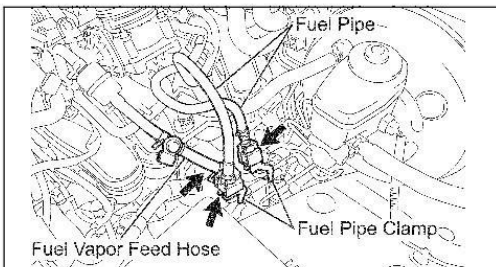

#### 25. RECONNECT THE FUEL PIPES

- Reconnect the No.1 and No.2 fuel pipe.
- Reinstall the 2 fuel pipe clamps.

#### 26. RECONNECT THE FUEL VAPOR FEED HOSE

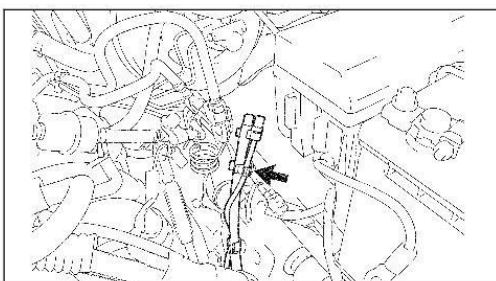

#### 27. RECONNECT THE FRONT DIFFERENTIAL BREATHER TUBES (4WD ONLY)

- Reconnect the front differential breather tubes.

**NOTE: There may be 2 different breather tubes depending on the vehicle spec.**

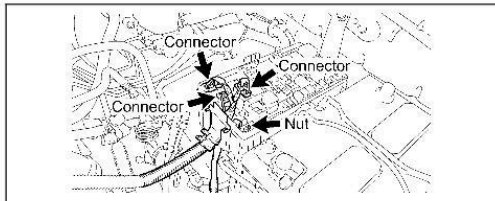

## 28. RECONNECT THE NO.2 ENGINE WIRE HARNESS

- a) Reinstall fuse box wire harness with the nut and torque to spec.

**Torque Spec: 12.7 N·m (130 kgf·cm, 9 ft·lbf)**

- b) Reconnect the 3 connectors.  
c) Reinstall the No.1 upper relay block cover.

- d) Reconnect the No.2 engine wire harness to the clip.  
e) Reinstall the (+) positive battery cable with the nut and torque to spec.

**Torque Spec: 12.7 N·m (130 kgf·cm, 9 ft·lbf)**

- f) Reinstall the ground wire with the bolt and torque to spec.

**Torque Spec: 8.3 N·m (85 kgf·cm, 73 in·lbf)**

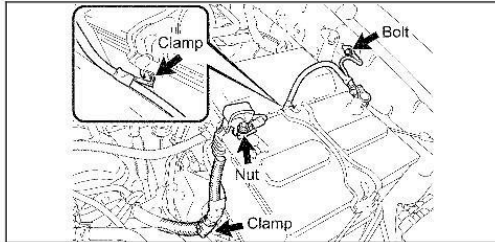

## 29. REINSTALL THE FOLLOWING PARTS

- Air Cleaner Hose and Air Cleaner Assy (*1GR-FE Only*)
  - **Torque Spec:**  
Air Cleaner Assy - 8.0 N·m (82 kgf·cm, 71 in·lbf)  
Air Cleaner Hose - 12 N·m (122 kgf·cm, 9 ft·lbf)
- Air Cleaner Hose and Air Cleaner Assy (*2TR-FE Only*)
  - **Torque Spec: 12 N·m (122 kgf·cm, 9 ft·lbf)**
- V-Bank Cover (*1GR-FE Only*)
  - **Torque Spec: 7.5 N·m (76 kgf·cm, 66 in·lbf)**

## 30. REINSTALL THE FOLLOWING PARTS

- Rear Floor Side Service Hole Cover LH/RH (*Access Cab*)
- Seat Floor Box (*Access Cab*)
- Floor Board No.1/No.2 (*Access Cab*)
- No.1 w/ Box Speaker Assy (*If Equipped*)
- Luggage compartment Side Tray (*Double Cab*)

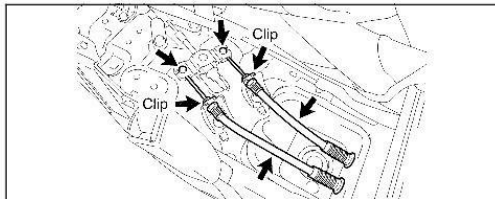

## 31. RECONNECT THE PARKING BRAKE CABLES

### For Separate Seat Type:

- a) Reconnect the 2 parking brake cables.  
b) Reinstall the 2 clips.

### For Bench Seat Type:

- c) Reconnect the 2 parking brake cables.  
d) Reinstall the 2 clips.

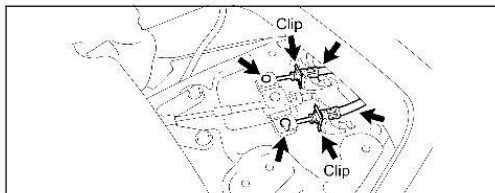

- e) Reinstall the parking brake cable joint protector with the 3 bolts and torque to spec.

**Torque Spec: 12.5 N·m (127 kgf·cm, 9 ft·lbf)**

- f) Turn back the floor carpet.

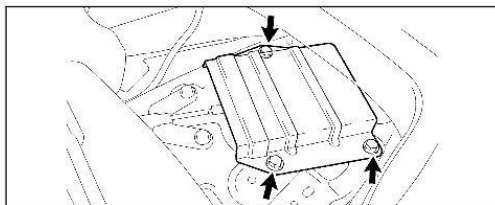



**36. REINSTALL THE FOLLOWING PARTS**

- Instrument Panel Box
- Cowl Side Trim Board LH/RH

- Front Floor Footrest
- Front Door Scuff Plate LH/RH

<b>NEW Replacement Parts</b>			
<b>Front No.2 Bumper Extension Sub-Assy LH/RH</b>			
Part #	Part Name	Kit #	Qty
90176-A0044	Nut, Flange	2	6

**37. REINSTALL THE FOLLOWING PARTS**

- Front No.2 Bumper Extension Sub-assy LH/RH
  - Reinstall the No.2 front bumper extension with 6 **NEW** nuts and torque to spec.
  - **Torque Spec: 58 N·m (591 kgf·cm, 43 ft·lbf)**
- Front Bumper Reinforcement
  - Reinstall the front bumper reinforcement with 6 nuts and torque to spec.
  - **Torque Spec: 58 N·m (591 kgf·cm, 43 ft·lbf)**
- Front Bumper Assy
  - Reinstall with the 6 screws and 9 clips.
- Front Fender Mudguard LH/RH
- Front Bumper Filler LH/RH
- Radiator Grille

**I. REINSTALL THE BED ASSY**

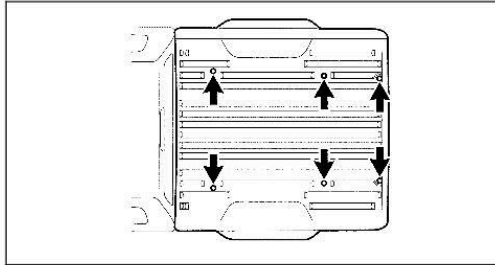

**1. REINSTALL THE BED ASSY**

- a) Using a Torx® T55 Socket, reinstall the bed assy Torx® bolts and torque to spec.

**Torque Spec: 49 N·m (500 kgf·cm, 36 ft·lbf)**

**NOTE:**

- Use 4 or more people to lift the bed assy.
- Evenly support the bed assy when reinstalling it.
- Be careful not to damage or hit the fuel inlet pipe when reinstalling the bed assy.

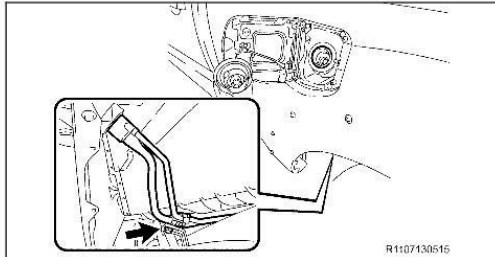

**2. REINSTALL THE FUEL INLET PIPE SUB-ASSY**

- a) Reinstall the fuel inlet pipe sub-assy with the 2 nuts and torque to spec.

**Torque Spec: 20 N·m (204 kgf·cm, 15 ft·lbf)**

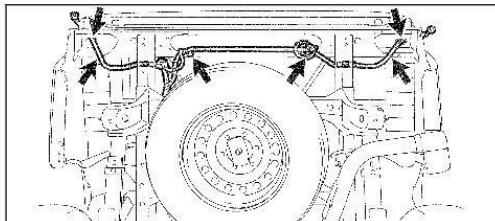

**3. RECONNECT THE FRAME WIRE HARNESS**

- a) Reconnect the 6 wire harness clamps to the bed assy.

**NOTE:**

- The number of connectors will differ depending on the vehicle spec.
- Use new clamps if the original ones are damaged.

**4. REINSTALL THE FOLLOWING PARTS**

- Left Rear Wheel Well Liner
- Quarter Panel Wheel Opening Molding
- Body Rocker Panel Molding Assy LH *(If Equipped)*
- Outside LH Back Door Molding Sub-Assy *(If Equipped)*
- Side Step Assy LH/RH *(If Equipped)*
- Rocker Panel Molding LH/RH *(If Equipped)*
- Rear Mudguard LH/RH *(If Equipped)*
- Rear Tail/Combination Light LH/RH
- Rear Bumper Assy
  - Reinstall the rear bumper assy with the 10 bolts and torque to spec. *(Trailer Hitch Equipped Vehicles Only)*
  - Reinstall the rear bumper assy with the 6 **NEW** bolts and torque to spec.
  - **Torque Spec: 90 N·m (918 kgf·cm, 66 ft·lbf)**

**NEW Replacement Parts**

**Left Rear Wheel Well Liner**

Part #	Part Name	Kit #	Qty
90189-A0002	Grommet, Screw (X-Runner)	9	6
90189-A0002	Grommet, Screw	8	8

**Quarter Panel Wheel Opening Molding**

Part #	Part Name	Kit #	Qty
75395-35070	Clip, Outside Molding, No. 1	8	3
75396-35020	Clip, Outside Molding, No. 2	8	7
90189-A0002	Grommet, Screw	8	2

**Body Rocker Panel Molding Assy LH**

Part #	Part Name	Kit #	Qty
75395-35070	Clip, Outside Molding, No. 1	9	2
75396-35020	Clip, Outside Molding, No. 2	9	1
90189-A0002	Grommet, Screw	9	1

**Outside LH Back Door Molding Sub-Assy**

Part #	Part Name	Kit #	Qty
75395-35070	Clip, Outside Molding, No. 1	9	2
75396-35020	Clip, Outside Molding, No. 2	9	1
90189-A0002	Grommet, Screw	9	1

**Rocker Panel Molding LH/RH**

Part #	Part Name	Kit #	Qty
75395-04010	Clip, Outside Molding, No. 1	9	4
75396-04010	Clip, Outside Molding, No. 2	9	14

**Rear Bumper Assy**

Part #	Part Name	Kit #	Qty
90119-A0192	Bolt, w/ Washer	2	6

**J. FINAL ASSEMBLY**

**1. REINSTALL THE NEGATIVE (-) BATTERY TERMINAL**

**NEW Replacement Parts**

**Front Differential**

Part #	Part Name	Kit #	Qty
12157-10010	Gasket, Drain Plug	3	1
90430-24003	Gasket	3	1

**2. REFILL THE FOLLOWING FLUIDS**

- Brake Fluid
    - Remove the brake tubes from the master cylinder.
    - Refill with Toyota Dot 3 Brake Fluid.
    - Bleed the master cylinder.
    - Reinstall the brake tubes to the master cylinder and torque to spec.
    - **Torque Spec: 15.2 N·m (155 kgf·cm, 11 ft·lbf)**
    - Refill with Toyota Dot 3 Brake Fluid.
    - Bleed the brake system at each wheel and torque the bleeder screws to spec.
    - **Torque Spec: 10.8 N·m (110 kgf·cm, 8 ft·lbf)**
  - Clutch Fluid (*1GR-FE Manual Trans Only*)
    - Refill with Toyota Dot 3 Brake Fluid.
    - Bleed the clutch system and torque the bleeder screws to spec.
    - **Torque Spec: 10.8 N·m (110 kgf·cm, 8 ft·lbf)**
- NOTE: 2TR Manual Trans uses master cylinder reservoir for clutch.**
- Coolant
    - Refill with Toyota Long Life Coolant.
    - Bleed the cooling system.
  - Front Differential
    - Install **NEW** drain plug washer and torque to spec.
    - **Torque Spec: 64.7 N·m (660 kgf·cm, 48 ft·lbf)**
    - Refill with Hypoid Gear Oil API GL-5 75W-90.
    - Install a **NEW** filler plug washer and torque to spec.
    - **Torque Spec: 39.2 N·m (400 kgf·cm, 29 ft·lbf)**

**3. START THE VEHICLE AND INSPECT THE FOLLOWING FOR LEAKS**

- Fuel System
  - Start the engine and let it run for 5 seconds, then stop the engine and inspect for leaks.
  - If there are no leaks, restart the engine and re-inspect.
- Cooling System
- Brake System
- Clutch System (*1GR-FE Manual Trans Only*)
- Front Differential System

**4. RECHARGE THE A/C SYSTEM AND CHECK FOR PROPER OPERATION AND REFRIGERANT LEAKS**

**5. CHECK THE OPERATION OF THE FOLLOWING SYSTEMS AND ADJUST AS NEEDED**

Make sure to follow the procedure outlined in the appropriate repair manual for the vehicle you are working on when checking, and if needed, adjusting the operation of the systems listed below. This is an important step, and must be performed thoroughly to ensure proper operation of these systems.

- Parking Brake Travel
- Shift Control Lever (**Automatic Transmission Vehicles Only**)
- Clutch Pedal (**Manual Transmission Vehicles Only**)

**6. CHECK ALL FLUID LEVELS AND ADJUST AS NEEDED**

NEW Replacement Parts			
Part #	Part Name	Kit #	Qty
43514-28010	Cap, FR Hub Grease	3	2
95381-04045	Pin, Cotter	3	2

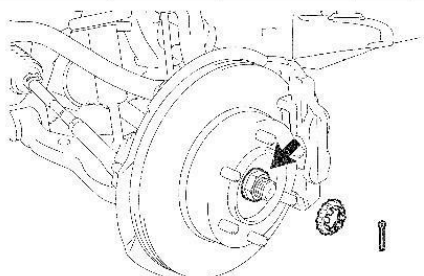

**7. TORQUE THE FRONT AXLE NUT (4WD ONLY)**

- a) Remove the front wheels.
  - b) Torque the front axle nut to spec.
- Torque Spec: 235 N·m (2396 kgf·cm, 173 ft·lb)**
- c) Reinstall the lock cap with the **NEW** cotter pin.
  - d) Reinstall the **NEW** grease cap.
  - e) Repeat the procedure on the opposite side.
  - f) Reinstall the front wheels and torque to spec.

**Torque Spec: 113 N·m (1152 kgf·cm, 83 ft·lbf)**

**NOTE: If the holes for the cotter pin are not aligned, tighten the axle nut further, up to 60°.**

**8. PERFORM A WHEEL ALIGNMENT**

**9. CHECK THE HEADLIGHT AIM AND ADJUST AS NEEDED**

NEW Replacement Parts			
Part Number	Part Name	Kit #	Qty
90080-11373	Bolt, w/ Washer	8	8

**10. REINSTALL THE ENGINE UNDER COVERS**

- a) Reinstall the engine under cover with **8 NEW** bolts and torque to spec.

**Torque Spec: 30 N·m (306 kgf·cm, 22 ft·lbf)**

**11. CHECK FOR DTC'S AND REPAIR AS NEEDED**

**12. PERFORM INITIALIZATION**

**13. FINAL INSPECTION**

- a) Check the operation of the following systems:
  - 4WD System (*4WD Only*)
  - Interior Lights
  - Exterior Lights
  - HVAC System
  - Audio System
- Power Windows
- Power Door Locks
- All Gauges, Indicators and Warning Lights
- Cooling Fans
- Etc.

**14. TEST DRIVE THE VEHICLE AND DOCUMENT FINAL REPAIR STATUS**

- a) Test drive the vehicle and perform final repair sign off with the [Frame Replacement Inspection Sheet](#). This must be performed and signed off by an MDT, Shop Foreman or Service Manager and retained with Final R.O.

**15. RECORD THE FRAME SERIAL NUMBER**

- a) Log into the frame tracker website using your dealer code and password.  
 URL: <https://zh-frame-tracker.imagespm.info/> Default password: xxxxx



b) Select 2005 to 2010 Tacoma ZH6 from the pick list.

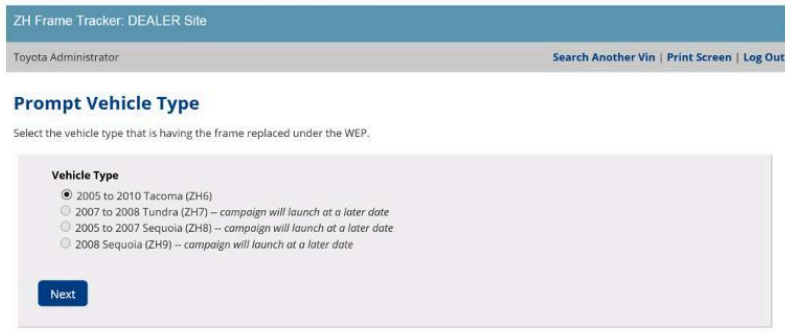

c) Enter the VIN of the vehicle.

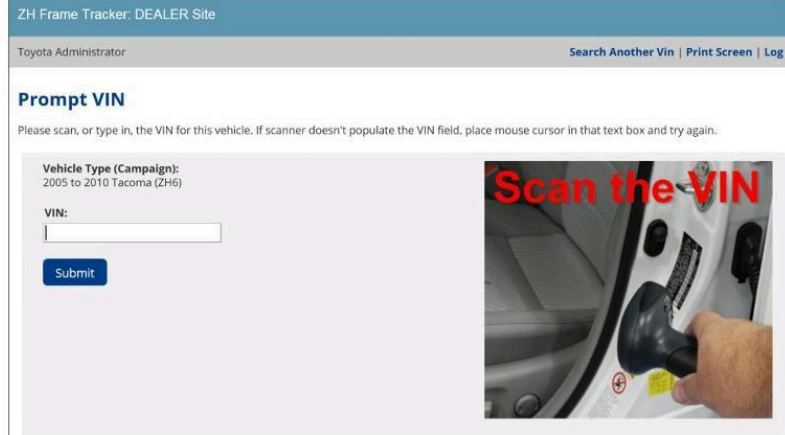

d) Enter the frame serial off of the case label along with the R.O. number and Approved Frame Inspection Case Number.

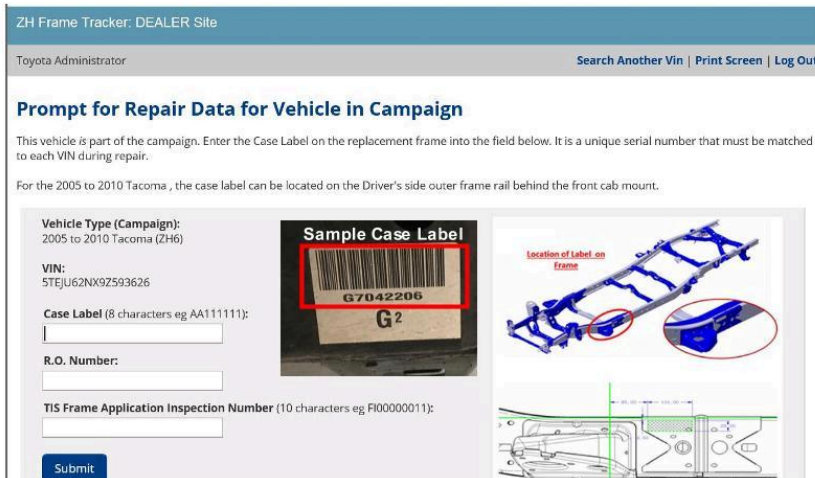

e) Press submit and print a copy of the serial number and file with the R.O.

## 1. APPENDIX

As required by Federal Regulations, please make sure all recalled parts (original parts) removed from the vehicle are disposed of in a manner in which they will not be reused. Adequate time has been provided in the repair time to cut up and dispose of the perforated frame.

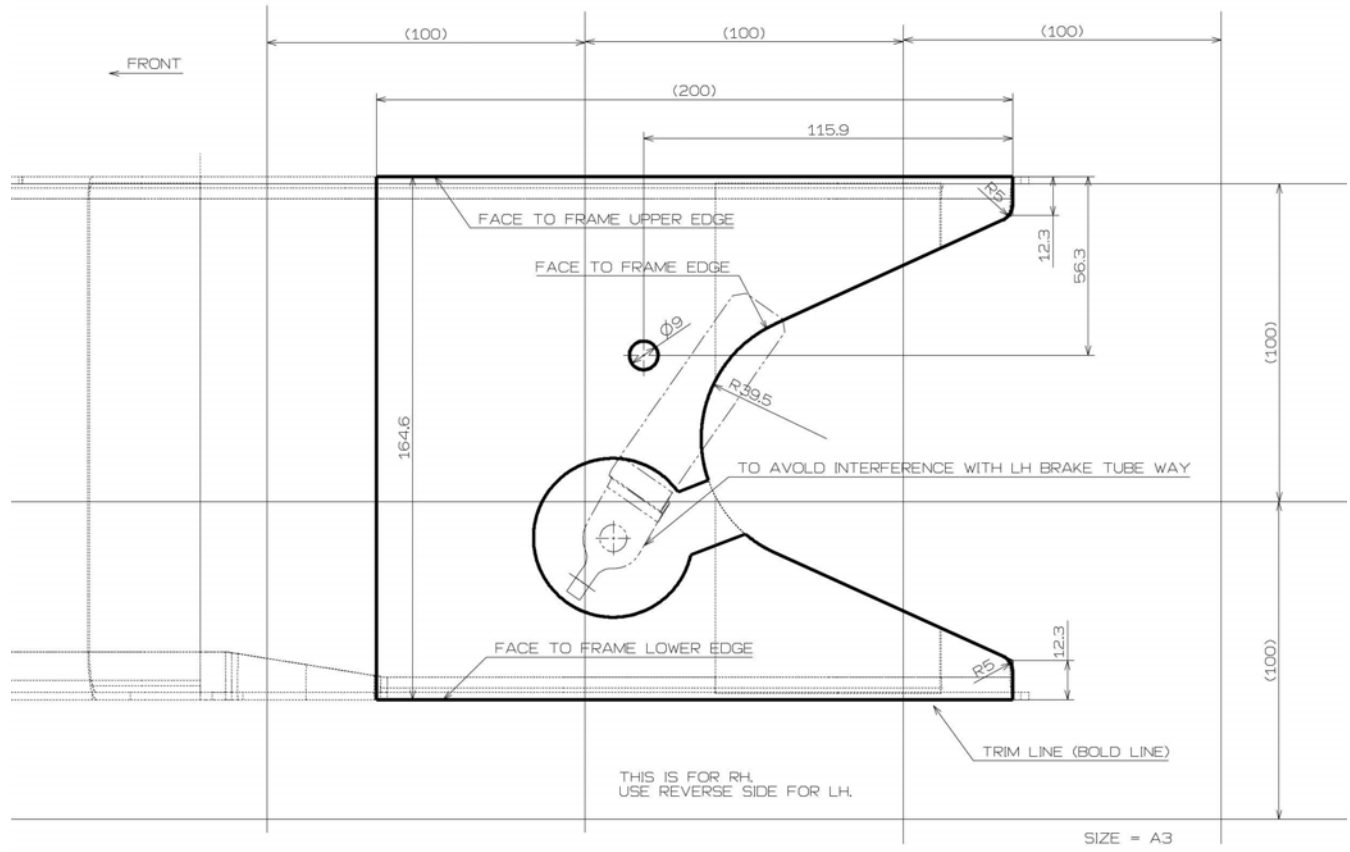

●● PROTECTED 関係者外秘

**IMPORTANT UPDATE****TECHNICAL INSTRUCTIONS****FOR****WARRANTY EXTENSION PROGRAM ZH6, ZH7, ZH8 AND ZH9****FRAME INSPECTION ONLY**

**CERTAIN 2005-2010 TACOMA (ZH6)  
CERTAIN 2007-2008 TUNDRA (ZH7)  
CERTAIN 2005-2007 SEQUOIA (ZH8)  
CERTAIN 2008 SEQUOIA (ZH9)**

**Updated 7-23-17**

- Updated to include picture size limitations for the inspection application and warning screen information. ([Section V.B.4.g](#))

The repair quality of covered vehicles is extremely important to Toyota. All dealership technicians performing this recall are required to successfully complete the most current version of the E-Learning course "Safety Recall and Service Campaign Essentials". To ensure that all vehicles have the repair performed correctly; technicians performing this repair are required to currently hold at least one of the following certification levels:

- Certified Technician (any specialty)
- Expert Technician (any specialty)
- Master Technician
- Master Diagnostic Technician

It is the dealership's responsibility to select technicians with the above certification level or greater to perform this recall repair. Carefully review your resources, the technician skill level, and ability before assigning technicians to this repair. It is important to consider technician days off and vacation schedules to ensure there are properly trained technicians available to perform this repair at all times.

●● PROTECTED 關係者外秘

## I. OPERATION FLOW CHART

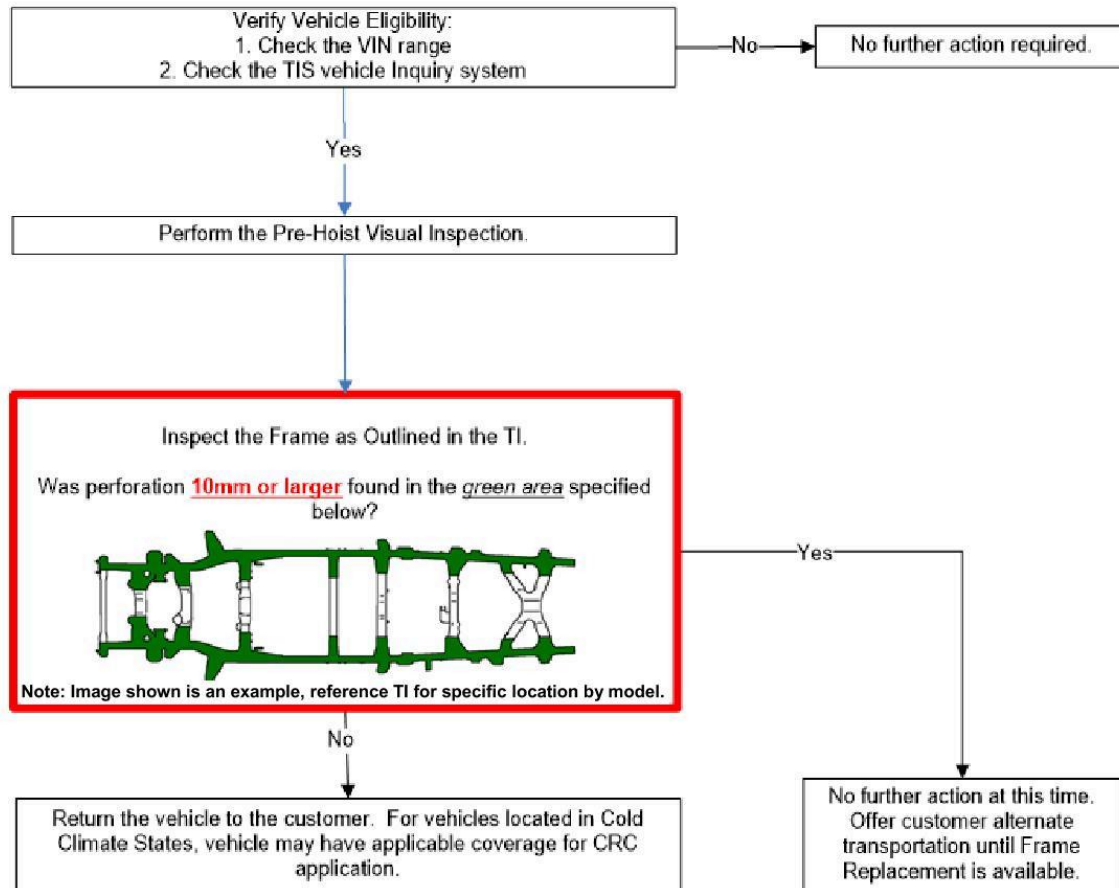

## II. IDENTIFICATION OF AFFECTED VEHICLES

- Check the TIS Vehicle Inquiry System to confirm the VIN is involved in this WEP, and that the it has not already been completed by another dealer.
- TMS warranty will not reimburse dealers for repairs completed on vehicles that are not affected or were completed by another dealer.

## III. PREPARATION

### A. PARTS

No parts required for inspection.

### B. TOOLS & EQUIPMENT

- Shop Light
- Mirror
- Camera

## IV. BACKGROUND

●● PROTECTED 關係者外秘

- Toyota has received reports that certain 2005-2010 Tacoma, 2007-2008 Tundra, and 2005-2008 Sequoia vehicles operated in specific cold climate areas (Cold Climate States) with high road salt usage may exhibit more-than-normal corrosion to the vehicle's frame.
- Toyota investigated these reports and determined that the frames in some vehicles may not have corrosion-resistant protection sufficient for use in these areas.
- This combined with prolonged exposure to road salts and other environmental factors, may contribute to the development of more-than-normal rust in the frame of some vehicles.
- This condition is unrelated to and separate from normal surface rust which is commonly found on metallic surfaces after some years of usage and/or exposure to the environment.

### V. FRAME INSPECTION

#### A. PERFORM INITIAL PRE-HOIST INSPECTION

1. INSPECT THE FRAME FOR EXCESSIVE FRAME CORROSION THAT COULD AFFECT THE STRUCTURAL INTEGRITY OF THE FRAME.

#### B. FRAME INSPECTION



#### 1. ACCESS INSPECTION APPLICATION

- a. Run the VIN in TIS and click on the Warranty Tab.
- b. Click on the "Frame Inspection" link on TIS.

The screenshot shows the TIS interface with the following details:

- Vehicle Information:** Division: TOYOTA, Model: Tacoma, Grade: PRERUNNER, Model Year: 2005. Drive Type: 2WD, Date of First Use: 03/23/2005, Body Type: Access Cab, Production Date: 02/04/2005, Engine Family: V6 - 1GR, Plant Code: Z - FREMONT PLANT - NUMMI, Engine No: 1GR0550396, Transmission: SAT. VIN: STE-TU62N-552048758.
- Accessories:** BU: BUCKET SEATS, CQ: CONVENIENCE PACKAGE, EN: POWER REMOTE OUTER MIRROR - BLACK, FE: 50 State Emissions, LF: FOG LAMPS, LX: SR5 PACKAGE WITH CHROME, SN: SR5 Package, #3: W: SLIDING REAR WINDOW.
- Service Campaign:** Campaign Description: Safety Recall E02 - Remedy Notice Certain 2005-2011 Model Year Tacoma Pre-Runner and 4x4 Vehicles Rear Leaf Spring. Completion Status: Not Completed. A 'Frame Inspection' link is circled in red.
- Tech Cert Requirements Table:**

Maint	Certified				Expert				Master	MDT	Special Courses	Addtl Info	
	EG	DT	CH	EL	EG	DT	CH	EL					HY
			✓				✓			✓	✓	(SC15A)	Remedy launched for vehicles in Boston, New York, CA, Cincinnati, Denver, Portland and Chicago regions.

●● PROTECTED 關係者外秘

### 2. LOG INTO THE INSPECTION APPLICATION

a. Reenter your TIS password

**Frame Inspection**

**Frame Inspection**

**Language:**  English  French  Spanish

Re-enter your TIS Password to proceed with the Frame Inspection

Verify the User ID currently logged into TIS matches the technician's User ID performing the Frame Inspection

TIS Password

### 3. ENTER VEHICLE INFORMATION

- a. Enter the vehicle mileage.
- b. Select the state from the drop down menu that the vehicle is registered.  
**Note: Do NOT select the state the dealership is located.**
- c. Inspect the frame for CRC compound that could have been previously applied:

**CRC was Previously Applied:** Select the CRC Bottle Button

**NO CRC Previously Applied:** Select Frame Button

**Note: CRC could only be previously applied to 2005 to 2008 Tacoma vehicles.**

**Frame Inspection**

**Frame Inspection Home**

<b>User ID</b> :	JOHNSO1459	<b>Technician Name</b> :	James Johnson
<b>Dealer Code</b> :	54012	<b>Dealer Name</b> :	CYPRESS COLLEGE
<b>Date/Time</b> :	07/08/2017 2:12 PM PDT	<b>VIN</b> :	5TBR38101S125908
		<b>DMY</b> :	TOYOTA Tundra 2001
<b>Vehicle Mileage</b> :	* <input type="text" value="120568"/> Miles	<b>Vehicle Registered State</b> :	* <input type="text" value="VT"/> ▼

Has the vehicle had CRC previously applied to the Frame?  
Click on the appropriate icon below to start the Frame inspection process.

  
CRC Previously Applied

  
No CRC Applied

●● PROTECTED 関係者外秘

**4. INSPECT THE FRAME SECTIONS**

a. Inspect the frame in the colored areas below and use the application to document the results of the inspection.

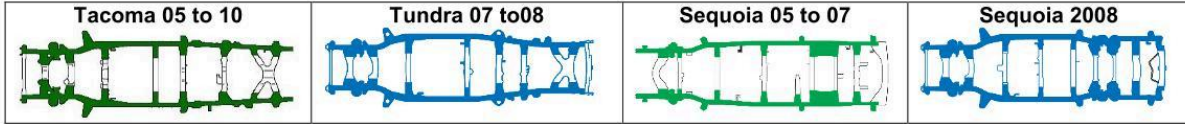

b. Select Section A

**Note: The frame inspection application must be completed in alphabetical order.**

**Frame Inspection**

Select Frame Section - NO CRC Applied

User ID	: JOHNSOJ459	Technician Name	: James Johnson
Dealer Code	: 54012	Dealer Name	: CYPRESS COLLEGE
Date/Time	: 07/08/2017 2:12 PM PDT	VIN	: STBRT38101S125908
Vehicle Mileage	: 120568 Miles	DMY	: TOYOTA Tundra 2001
		Vehicle Registered State	: VT

Click on the highlighted section of the frame diagram below to start the inspection process.  
Each section of the frame must be inspected as instructed by the Technical Instructions.  
You must start in Section A (Front Passenger Side of the vehicle) and proceed to each section in alphabetical order.

Back

c. Inspect the frame section and inspect all surfaces of the frame rail and crossmember. Select the photo that best represents the frame condition. If perforation of 10mm or larger is identified select "Peroration of the Frame".

**Note: You must click the bubble next to the image to select the condition.**

**Frame Inspection**

Select Frame Condition - NO CRC Applied

Inspect the frame condition as described in the technical instructions. Ensure to inspect the exterior and interior facing surfaces of the frame rail, along with the crossmembers of the frame. Identify the overall condition of the frame by selecting the appropriate image that best represents the condition of the frame section.  
You must click on the bubble next to the image to make your selection.  
Note: If there is perforation in any part of the identified frame section always select perforation.

<input type="radio"/>		<input type="radio"/>		<input type="radio"/>		<input checked="" type="radio"/>	
	E-Coat Intact		Light to Moderate Surface Rust		Complete Surface Rust with Rust Scales		Perforation of the Frame

Back Clear Next

●● PROTECTED 関係者外秘

- d. If you selected Perforation of the Frame, the application will request more information about the size of perforation(s) and location.
- e. The section with perforation will split into 2 sub-sections to further identify the perforation location.
- f. Select the size of the perforation in each sub-section.
- g. Upload a photo for each area containing perforation and describe the location in the comments section.

**Note:**

- **Include the R.O in the image of at least one of the perforation holes.**
  - **If both sub-sections have perforation, it will require two pictures to be uploaded.**
  - **If perforation was accidentally selected, use the back button to reset section.**
- h. Select Next to move onto the next section.

The screenshot shows a web form titled "Frame Inspection" with the sub-header "Select Perforation Identification - NO CRC Applied". Below the header, there is explanatory text: "The frame section has been split into two smaller sections to help clarify to the technical staff where the perforation is located. Please select the location and size of the perforation and upload an image of the perforation." and a note: "Note: If perforation is found in both areas please identify both perforation locations below." The form is divided into two columns, A1 and A2. Each column has a diagram of a frame section, a heading "Check the appropriate perforation size\*", and three radio button options: "Perforation Found during Frame Clearing for CRC-10mm and above", "16mm or above", and "10 to 15mm", and "None". Below the radio buttons is a "Comments: (500 Chars)" field with a dropdown menu. At the bottom of each column is an "Upload Images" section with a "Choose File" button and a small image thumbnail. The A1 section has a thumbnail labeled "IMG\_1302.JPG". At the bottom right of the form are "Back", "Clear", and "Next" buttons.

**STOP** Each image attached has a size limit of 3 MB and all images cannot exceed 15 MB total. If 3MB is uploaded the system will display the error shown below.

User using Chrome browser may receive intermittent errors when uploading several high quality images, IE is recommended.

This screenshot shows the same "Frame Inspection" form as above, but with an error message "Please Upload file less than 3MB" highlighted in a red box at the top left. The form is now for sections B1 and B2. The radio button options are "Perforation Found during Frame Clearing for CRC-10mm and above", "16mm or above", "10 to 15mm", and "None". The "Comments: (500 Chars)" field is empty. The "Upload Images" section shows "Choose File" and "No file chosen". The "Back", "Clear", and "Next" buttons are at the bottom right.

●● PROTECTED 関係者外秘

i. Once all sections have been completed, select the Submit button.

**Note: When completed it will be indicated by all sections being grayed out and the submit button will appear.**

Frame Inspection - NO CRC Applied

User ID	: JOHNSOJ459	Technician Name	: James Johnson
Dealer Code	: 54012	Dealer Name	: CYPRESS COLLEGE
Date/Time	: 07/08/2017 2:12 PM PDT	VIN	: 5TBRT38101S125908
Vehicle Mileage	:* 120568 Miles	DMY	: TOYOTA Tundra 2001
		Vehicle Registered State	:* VT

Front

Rear

[Back](#) [Submit](#)

**NO Perforation Found**

j. If no perforation was not found, follow the directions as provided.

Frame Inspection - NO CRC Applied

User ID	: JOHNSOJ459	Technician Name	: James Johnson
Dealer Code	: 54012	Dealer Name	: CYPRESS COLLEGE
Date/Time	: 07/08/2017 2:12 PM PDT	VIN	: 5TBRT38101S125908
Vehicle Mileage	:* 120568 Miles	DMY	: TOYOTA Tundra 2001
		Vehicle Registered State	:* VT

Frame Inspection Case: FI000000881  
Inspection Summary: **NO Perforation**

**Perforation Found**

k. If perforation was found, this application will be submitted to your Regional Office for review. The region office will review the inspection and provide feedback if the frame replacement is approved

DO NOT proceed with frame replacement or parts ordering until you are provided with approval from the Regional Office. Approval will be sent to the inspection technician's TIS inbox and Service and Parts Manager email. Repairs cannot start until the remedy is launched for this WEP.

for future repair.

Frame Inspection - NO CRC Applied

User ID	: JOHNSOJ459	Technician Name	: James Johnson
Dealer Code	: 54012	Dealer Name	: CYPRESS COLLEGE
Date/Time	: 07/08/2017 2:12 PM PDT	VIN	: 5TBRT38101S125908
Vehicle Mileage	:* 120568 Miles	DMY	: TOYOTA Tundra 2001
		Vehicle Registered State	:* VT

Frame Inspection Case: FI000000881  
Inspection Summary: Perforation has been found in Sections A1,C1,C2.  
Toyota Technical Staff will review and provide feedback or authorization for repair. Feedback and authorization will be sent to your TIS inbox when the review has been completed.

[Close](#)